

HITACHI INVERTER

SJ700-2 SERIES

SERVICE MANUAL

After reading this manual, keep it handy for future reference.

NTS204X

HITACHI

Revision History

No.	Revision content	Date of issue	Manual code
1	First edition	October 2007	NTS204X

- The current edition of this Instruction Manual also includes some corrections of simple misprints, missing letters, misdescriptions and certain added explanations other than those listed in the above Revision History table.

Table of contents

Chapter 1 Investigation of the inverter

1.1	Specification label(Model name,manufacturing number:MFG)	1 - 1
1.1.1	Model name,	1 - 1
1.1.2	MFG number	1 - 1
1.2	Precautions for Data Setting	1 - 2
1.2.1	Monitor Mode	1 - 2
1.2.2	Function Mode	1 - 3
1.2.3	Extended Function Mode	1 - 4
1.3	Code display system and key operations	1 - 20
1.3.1	Example of operation in basic display mode("b037"="04"[factory setting])	1 - 21
1.3.2	Example of operation in full display mode("b037"="00"[factory setting])	1 - 23
1.3.3	Code/data display and key operator in extended function mode U	1 - 24

Chapter 2 Troubleshooting

2.1	Inverter trip contents,remedy,advise	2 - 1
2.2	Option board error codes	2 - 5
2.2.1	Error indications by protective functions with the feedback option board (SJ-FB) mounted	2 - 5
2.2.2	Error indications by protective functions with the digital option board (SJ-DG) mounted	2 - 6
2.2.3	Error indications by protective functions with the DeviceNet option board (SJ-DN) mounted	2 - 7
2.2.4	Error indications by protective functions with the easy sequence function used	2 - 8
2.3	Trip conditions monitoring	2 - 9
2.4	Warning Codes	2 - 10
2.5	Initialization setting	2 - 11

Chapter 3 Debug Mode

3.1	Monitor Modes	3 - 1
3.2	Function Modes	3 - 2
3.3	How To Reference the Data Area (d105) Corresponding to Trip History	3 - 2
3.4	Inverter Setting	3 - 3
3.4.1	Setting procedure	3 - 3
3.4.2	Confirming the completion of initialization	3 - 4

Chapter 4 The check of control power supply voltage and a control signal

4.1	Control power supply	4 - 1
4.2	Control signal	4 - 1

Chapter 5 Maintenance and Inspection

5.1	Precautions for Maintenance and Inspection	5 - 1
5.1.1	Daily inspection	5 - 1
5.1.2	Cleaning	5 - 1
5.1.3	Periodic inspection	5 - 1
5.2	Daily and Periodic Inspections	5 - 2
5.3	Ground Resistance Test with a Megger	5 - 3
5.4	Withstand Voltage Test	5 - 3
5.5	Method of Checking the Inverter and Converter Circuits	5 - 4
5.6	Replacing Parts	5 - 5
5.7	Inverter Replacement	5 - 8

Appendix

Circuit Diagram6 - 1
Internal block diagram6 - 2
Structure figure6 - 15

1. Investigation of the inverter

1.1 Specification label(Model name,Manufacturing number:MFG)

·There is a specification label attached to the inverter as shown in Figure 1-1.

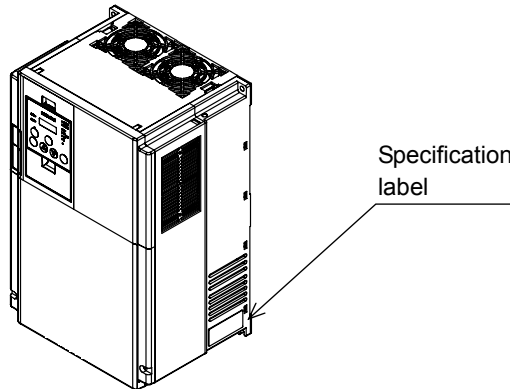

Figure 1-1 Location of the specifications label

·Please confirm the model name and MFG number from the specification label as follows.

Inverter model	Model: SJ700-150HFF2	HITACHI			
Maximum applicable motor capacity	kW/(HP): 15/(20)				
Input ratings	Input/Entree: 50Hz, 60Hz	V	1 Ph	A	
Output ratings	50Hz, 60Hz	380-480V	3 Ph	35A	
Serial number	Output/Sortie: 0-400Hz	380-480V	3 Ph	32A	
	MFGNo. 77AAT12345 A 001	Date: 0707			
	Hitachi Industrial Equipment Systems Co., Ltd.		MADE IN JAPAN	NE	

Figure 1-2 Contents of the specifications label

1.1.1 Model name

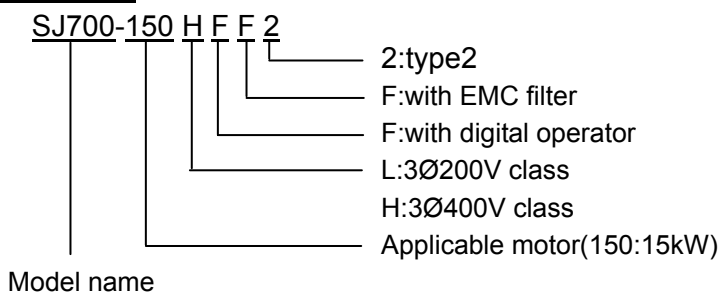

1.1.2 MFG number

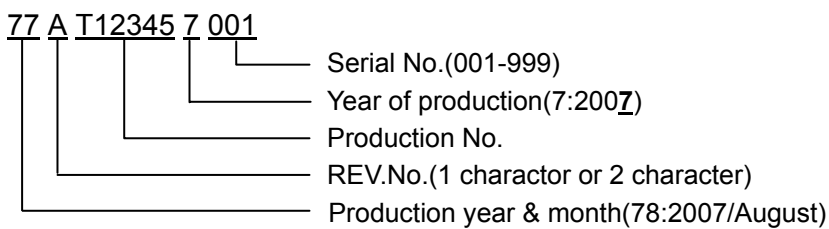

1.2 Precautions for Data Setting

The default display mode limits the screens (parameters) that can be displayed on the monitor. To enable the display of all parameters, specify "00" (full display) for the function code display restriction (b037).

To enable the parameters to be changed while the inverter is operating, specify "10" for the software lock mode selection (b031).

1.2.1 Monitoring Mode

Code	Function name	Monitored data or setting	Default	Note
d001	Output frequency monitoring	0.00 to 99.99, 100.0 to 400.0 (Hz)	-	
d002	Output current monitoring	0.0 to 999.9, 1000 to 9999 (A)	-	
d003	Rotation direction monitoring	F (forward rotation), o (stopped), r (reverse rotation)	-	
d004	Process variable (PV), PID feedback monitoring	0.00 to 99.99, 100.0 to 999.9, 1000. to 9999. 1000 to 9999 (10000 to 99990), 100 to 999 (100000 to 999000)	-	
d005	Intelligent input terminal status	<p>(Example) Terminals FW, 7, 2, and 1: ON Terminals 8, 6, 5, 4, and 3: OFF</p>	-	
d006	Intelligent output terminal status	<p>(Example) Terminals 12 and 11: ON Terminals AL, 15, 14, and 13: OFF</p>	-	
d007	Scaled output frequency monitoring	0.00 to 99.99, 100.0 to 999.9, 1000. to 9999., 1000 to 3996 (10000 to 39960)	-	
d008	Actual-frequency monitoring	-400. to -100., -99.9 to 0.00 to 99.99, 100.0 to 400.0 (Hz)	-	
d009	Torque command monitoring	-200. to +200. (%)	-	
d010	Torque bias monitoring	-200. to +200. (%)	-	
d012	Torque monitoring	-200. to +200. (%)	-	
d013	Output voltage monitoring	0.0 to 600.0 (V)	-	
d014	Power monitoring	0.0 to 999.9 (kW)	-	
d015	Cumulative power monitoring	0.0 to 999.9, 1000. to 9999. 1000 to 9999 (10000 to 99990), 100 to 999 (100000 to 999000)	-	
d016	Cumulative operation RUN time monitoring	0. to 9999., 1000 to 9999 (10000 to 99990), 100 to 999 (100000 to 999000) (hr)	-	
d017	Cumulative power-on time monitoring	0. to 9999., 1000 to 9999 (10000 to 99990), 100 to 999 (100000 to 999000) (hr)	-	
d018	Heat sink temperature monitoring	-020. to 200.0 (°C)	-	
d019	Motor temperature monitoring	-020. to 200.0 (°C)	-	
d022	Life-check monitoring	<p>1: Capacitor on main circuit board 2: Cooling-fan speed drop</p>	-	
d023	Program counter	0 to 1024	-	
d024	Program number monitoring	0000 to 9999	-	

Code	Function name	Monitored data or setting	Default	Note
d025	User monitor 0	-2147483647 to 2147483647 (upper 4 digits including "-")	-	
d026	User monitor 1	-2147483647 to 2147483647 (upper 4 digits including "-")	-	
d027	User monitor 2	-2147483647 to 2147483647 (upper 4 digits including "-")	-	
d028	Pulse counter	0 to 2147483647 (upper 4 digits)	-	
d029	Position setting monitor	-1073741823 to 1073741823 (upper 4 digits including "-")	-	
d030	Position feedback monitor	-1073741823 to 1073741823 (upper 4 digits including "-")	-	
d080	Trip Counter	0. to 9999., 1000 to 6553 (10000 to 65530) (times)	-	
d081	Trip monitoring 1	Factor, frequency (Hz), current (A), voltage across P-N (V), running time (hours), power-on time (hours)	-	
d082	Trip monitoring 2	Factor, frequency (Hz), current (A), voltage across P-N (V), running time (hours), power-on time (hours)	-	
d083	Trip monitoring 3	Factor, frequency (Hz), current (A), voltage across P-N (V), running time (hours), power-on time (hours)	-	
d084	Trip monitoring 4	Factor, frequency (Hz), current (A), voltage across P-N (V), running time (hours), power-on time (hours)	-	
d085	Trip monitoring 5	Factor, frequency (Hz), current (A), voltage across P-N (V), running time (hours), power-on time (hours)	-	
d086	Trip monitoring 6	Factor, frequency (Hz), current (A), voltage across P-N (V), running time (hours), power-on time (hours)	-	
d090	Programming error monitoring	Warning code	-	
d102	DC voltage monitoring	0.0 to 999.9 (V)	-	
d103	BRD load factor monitoring	0.0 to 100.0 (%)	-	
d104	Electronic thermal overload monitoring	0.0 to 100.0 (%)	-	

1.2.2 Function Mode

Code	Function name	Monitored data or setting	Default		
			_FF	_FEF	_FUF
F001	Output frequency setting	0.0, "start frequency" to "maximum frequency" (or maximum frequency, 2nd/3rd motors) (Hz) 0.0 to 100.0 (when PID function is enabled)	0.00		
F002	Acceleration (1) time setting	0.01 to 99.99, 100.0 to 999.9, 1000. to 3600. (s)	30.00		
F202	Acceleration (1) time setting, 2nd motor	0.01 to 99.99, 100.0 to 999.9, 1000. to 3600. (s)	30.00		
F302	Acceleration (1) time setting, 3rd motor	0.01 to 99.99, 100.0 to 999.9, 1000. to 3600. (s)	30.00		
F003	Deceleration (1) time setting	0.01 to 99.99, 100.0 to 999.9, 1000. to 3600. (s)	30.00		
F203	Deceleration time setting, 2nd motor	0.01 to 99.99, 100.0 to 999.9, 1000. to 3600. (s)	30.00		
F303	Deceleration time setting, 3rd motor	0.01 to 99.99, 100.0 to 999.9, 1000. to 3600. (s)	30.00		
F004	Keypad Run key routing	00 (forward rotation), 01 (reverse rotation)	00		

1.2.3 Extended Function Mode

Code	Function name	Monitored data or setting	Default			Note
			_FF	_FEF	_FUF	
Basic settings	A001	Frequency source setting	00 (keypad potentiometer) (*1), 01 (control circuit terminal block), 02 (digital operator), 03 (RS485), 04 (option 1), 05 (option 2), 06 (pulse-string input), 07 (easy sequence), 10 (operation function result)			
	A002	Run command source setting	01 (control circuit terminal block), 02 (digital operator), 03 (RS485), 04 (option 1), 05 (option 2)			
	A003	Base frequency setting	30. to "maximum frequency" (Hz)			
	A203	Base frequency setting, 2nd motor	30. to "maximum frequency, 2nd motor" (Hz)			
	A303	Base frequency setting, 3rd motor	30. to "maximum frequency, 3rd motor" (Hz)			
	A004	Maximum frequency setting	30. to 400. (Hz)			
	A204	Maximum frequency setting, 2nd motor	30. to 400. (Hz)			
	A304	Maximum frequency setting, 3rd motor	30. to 400. (Hz)			
Analog input and others	A005	[AT] selection	00 (switching between O and OI terminals), 01 (switching between O and O2 terminals), 02 (switching between O terminal and keypad potentiometer) (*1), 03 (switching between OI terminal and keypad potentiometer) (*1), 04 (switching between O2 and keypad potentiometer) (*1)			
	A006	[O2] selection	00 (single), 01 (auxiliary frequency input via O and OI terminals) (nonreversible), 02 (auxiliary frequency input via O and OI terminals) (reversible), 03 (disabling O2 terminal)			
	A011	[O]-[L] input active range start frequency	0.00 to 99.99, 100.0 to 400.0 (Hz)			
	A012	[O]-[L] input active range end frequency	0.00 to 99.99, 100.0 to 400.0 (Hz)			
	A013	[O]-[L] input active range start voltage	0. to "[O]-[L] input active range end voltage" (%)			
	A014	[O]-[L] input active range end voltage	"[O]-[L] input active range start voltage" to 100. (%)			
	A015	[O]-[L] input active range start frequency selection	00 (external start frequency), 01 (0 Hz)			
	A016	External frequency filter time const.	1. to 30. or 31. (500 ms filter ±0.1 Hz with hysteresis)			
Multispeed operation and jogging	A017	Easy sequence function selection	00 (disabling), 01 (enabling)			
	A019	Multispeed operation selection	00 (binary: 16 speeds selectable with 4 terminals), 01 (bit: 8 speeds selectable with 7 terminals)			
	A020	Multispeed frequency setting	0.0 or "start frequency" to "maximum frequency" (Hz)			
	A220	Multispeed frequency setting, 2nd motor	0.0 or "start frequency" to "maximum frequency, 2nd motor" (Hz)			
	A320	Multispeed frequency setting, 3rd motor	0.0 or "start frequency" to "maximum frequency, 3rd motor" (Hz)			
	A021	Multispeed 1 setting	0.0 or "start frequency" to "1st maximum frequency" (Hz)			
	A022	Multispeed 2 setting	0.0 or "start frequency" to "2nd maximum frequency" (Hz)			
	A023	Multispeed 3 setting	0.0 or "start frequency" to "3rd maximum frequency" (Hz)			
	A024	Multispeed 4 setting	0.0 or "start frequency" to "n-th maximum frequency" (Hz)			
	A025	Multispeed 5 setting	0.0 or "start frequency" to "n-th maximum frequency" (Hz)			
	A026	Multispeed 6 setting	0.0 or "start frequency" to "n-th maximum frequency" (Hz)			
	A027	Multispeed 7 setting	0.0 or "start frequency" to "n-th maximum frequency" (Hz)			
	A028	Multispeed 8 setting	0.0 or "start frequency" to "n-th maximum frequency" (Hz)			
	A029	Multispeed 9 setting	0.0 or "start frequency" to "n-th maximum frequency" (Hz)			
	A030	Multispeed 10 setting	0.0 or "start frequency" to "n-th maximum frequency" (Hz)			
	A031	Multispeed 11 setting	0.0 or "start frequency" to "n-th maximum frequency" (Hz)			
	A032	Multispeed 12 setting	0.0 or "start frequency" to "n-th maximum frequency" (Hz)			
	A033	Multispeed 13 setting	0.0 or "start frequency" to "n-th maximum frequency" (Hz)			
	A034	Multispeed 14 setting	0.0 or "start frequency" to "n-th maximum frequency" (Hz)			
	A035	Multispeed 15 setting	0.0 or "start frequency" to "n-th maximum frequency" (Hz)			
A038	Jog frequency setting	"Start frequency" to 9.99 (Hz)				
A039	Jog stop mode	00 (free-running after jogging stops [disabled during operation]), 01 (deceleration and stop after jogging stops [disabled during operation]), 02 (DC braking after jogging stops [disabled during operation]), 03 (free-running after jogging stops [enabled during operation]), 04 (deceleration and stop after jogging stops [enabled during operation]), 05 (DC braking after jogging stops [enabled during operation])				

Code	Function name	Monitored data or setting	Default			Note
			_FF	_FEF	_FUF	
V/f characteristic	A041	Torque boost method selection	00 (manual torque boost), 01 (automatic torque boost)			00
	A241	Torque boost method selection, 2nd motor	00 (manual torque boost), 01 (automatic torque boost)			00
	A042	Manual torque boost value	0.0 to 20.0 (%)			1.0
	A242	Manual torque boost value, 2nd motor	0.0 to 20.0 (%)			1.0
	A342	Manual torque boost value, 3rd motor	0.0 to 20.0 (%)			1.0
	A043	Manual torque boost frequency adjustment	0.0 to 50.0 (%)			5.0
	A243	Manual torque boost frequency adjustment, 2nd motor	0.0 to 50.0 (%)			5.0
	A343	Manual torque boost frequency adjustment, 3rd motor	0.0 to 50.0 (%)			5.0
	A044	V/F characteristic curve selection, 1st motor	00 (VC), 01 (VP), 02 (free V/f), 03 (sensorless vector control), 04 (0Hz-range sensorless vector), 05 (vector with sensor)			00
	A244	V/F characteristic curve selection, 2nd motor	00 (VC), 01 (VP), 02 (free V/f), 03 (sensorless vector control), 04 (0Hz-range sensorless vector)			00
	A344	V/F characteristic curve selection, 3rd motor	00(VC), 01(VP)			00
	A045	V/f gain setting	20. to 100. (%)			100.
	A046	Voltage compensation gain setting for automatic torque boost, 1st motor	0. to 255.			100.
	A246	Voltage compensation gain setting for automatic torque boost, 2nd motor	0. to 255.			100.
	A047	Slippage compensation gain setting for automatic torque boost, 1st motor	0. to 255.			100.
A247	Slippage compensation gain setting for automatic torque boost, 2nd motor	0. to 255.			100.	
DC braking	A051	DC braking enable	00 (disabling), 01 (enabling), 02 (set frequency only)			00
	A052	DC braking frequency setting	0.00 to 99.99, 100.0 to 400.0 (Hz)			0.50
	A053	DC braking wait time	0.0 to 5.0 (s)			0.0
	A054	DC braking force during deceleration	0. to 100. (%)			0.
	A055	DC braking time for deceleration	0.0 to 60.0 (s)			0.0
	A056	DC braking/edge or level detection for [DB] input	00 (edge operation), 01 (level operation)			01
	A057	DC braking force for starting	0. to 100.(%)			0.
	A058	DC braking time for starting	0.0 to 60.0(s)			0.0
	A059	DC braking carrier frequency setting	0.5 to 15.0(kHz)			5.0
Frequency upper/lower limit and jump frequency	A061	Frequency upper limit setting	0.00 or "1st minimum frequency limit" to "maximum frequency" (Hz)			0.00
	A261	Frequency upper limit setting, 2nd motor	0.00 or "2nd minimum frequency limit" to "maximum frequency, 2nd motor" (Hz)			0.00
	A062	Frequency lower limit setting	0.00 or "start frequency" to "maximum frequency limit" (Hz)			0.00
	A262	Frequency lower limit setting, 2nd motor	0.00 or "start frequency" to "maximum frequency, 2nd motor limit" (Hz)			0.00
	A063	Jump (center) frequency setting 1	0.00 to 99.99, 100.0 to 400.0 (Hz)			0.00
	A064	Jump (hysteresis) frequency width setting 1	0.00 to 10.00 (Hz)			0.50
	A065	Jump (center) frequency setting 2	0.00 to 99.99, 100.0 to 400.0 (Hz)			0.00
	A066	Jump (hysteresis) frequency width setting 2	0.00 to 10.00 (Hz)			0.50
	A067	Jump (center) frequency setting 3	0.00 to 99.99, 100.0 to 400.0 (Hz)			0.00
	A068	Jump (hysteresis) frequency width setting 3	0.00 to 10.00 (Hz)			0.50
	A069	Acceleration stop frequency setting	0.00 to 99.99, 100.0 to 400.0 (Hz)			0.00
A070	Acceleration stop time frequency setting	0.0 to 60.0 (s)			0.0	
PID control	A071	PID Function Enable	00 (disabling), 01 (enabling), 02 (enabling inverted-data output)			00
	A072	PID proportional gain	0.2 to 5.0			1.0
	A073	PID integral time constant	0.0 to 999.9, 1000. to 3600. (s)			1.0
	A074	PID derivative gain	0.00 to 99.99, 100.0 (s)			0.00
	A075	PV scale conversion	0.01 to 99.99			1.00
	A076	PV source setting	00 (input via OI), 01 (input via O), 02 (external communication), 03 (pulse-string frequency input), 10 (operation result output)			00
	A077	Output of inverted PID deviation	00(OFF), 01 (ON)			00
	A078	PID variation range	0.0 to 100.0 (%)			0.00
	A079	PID feed forward selection	00 (disabled), 01 (O input), 02 (OI input), 03 (O2 input)			00

Code	Function name	Monitored data or setting	Default			Note
			_FF	_FEF	_FUF	
AVR	A081	AVR function select	00 (always on), 01 (always off), 02 (off during deceleration)			
	A082	AVR voltage select	200 V class: 200, 215, 220, 230, 240 (V) 400 V class: 380, 400, 415, 440, 460, 480 (V)			
Operation mode and acceleration/deceleration function	A085	Operation mode selection	00 (normal operation), 01 (energy-saving operation), 02 (fuzzy operation)			
	A086	Energy saving mode tuning	0.1 to 100.0			
	A092	Acceleration (2) time setting	0.01 to 99.99, 100.0 to 999.9, 1000. to 3600. (s)			
	A292	Acceleration (2) time setting, 2nd motor	0.01 to 99.99, 100.0 to 999.9, 1000. to 3600. (s)			
	A392	Acceleration (2) time setting, 3rd motor	0.01 to 99.99, 100.0 to 999.9, 1000. to 3600. (s)			
	A093	Deceleration (2) time setting	0.01 to 99.99, 100.0 to 999.9, 1000. to 3600. (s)			
	A293	Deceleration (2) time setting, 2nd motor	0.01 to 99.99, 100.0 to 999.9, 1000. to 3600. (s)			
	A393	Deceleration (2) time setting, 3rd motor	0.01 to 99.99, 100.0 to 999.9, 1000. to 3600. (s)			
	A094	Select method to switch to Acc2/Dec2 profile	00 (switching by 2CH terminal), 01 (switching by setting), 02 (switching only when rotation is reversed)			
	A294	Select method to switch to Acc2/Dec2, 2nd motor	00 (switching by 2CH terminal), 01 (switching by setting), 02 (switching only when rotation is reversed)			
	A095	Acc1 to Acc2 frequency transition point	0.00 to 99.99, 100.0 to 400.0 (Hz)			
	A295	Acc1 to Acc2 frequency transition point, 2nd motor	0.00 to 99.99, 100.0 to 400.0 (Hz)			
	A096	Dec1 to Dec2 frequency transition point	0.00 to 99.99, 100.0 to 400.0 (Hz)			
	A296	Dec1 to Dec2 frequency transition point, 2nd motor	0.00 to 99.99, 100.0 to 400.0 (Hz)			
A097	Acceleration curve selection	00 (linear), 01 (S curve), 02 (U curve), 03 (inverted-U curve), 04 (EL-S curve)				
A098	Deceleration curve setting	00 (linear), 01 (S curve), 02 (U curve), 03 (inverted-U curve), 04 (EL-S curve)				
External frequency adjustment	A101	[OI]-[L] input active range start frequency	0.00 to 99.99, 100.0 to 400.0 (Hz)			
	A102	[OI]-[L] input active range end frequency	0.00 to 99.99, 100.0 to 400.0 (Hz)			
	A103	[OI]-[L] input active range start current	0. to "[OI]-[L] input active range end current" (%)			
	A104	[OI]-[L] input active range end current	"[OI]-[L] input active range start current" to 100. (%)			
	A105	[OI]-[L] input start frequency enable	00 (external start frequency), 01 (0 Hz)			
	A111	[O2]-[L] input active range start frequency	-400. to -100., -99.9 to 0.00 to 99.99, 100.0 to 400.0 (Hz)			
	A112	[O2]-[L] input active range end frequency	-400. to -100., -99.9 to 0.00 to 99.99, 100.0 to 400.0 (Hz)			
	A113	[O2]-[L] input active range start voltage	-100. to 02 end-frequency rate (%)			
A114	[O2]-[L] input active range end voltage	"02 start-frequency rate" to 100. (%)				
n and deceleration	A131	Acceleration curve constants setting	01 (smallest swelling) to 10 (largest swelling)			
	A132	Deceleration curve constants setting	01 (smallest swelling) to 10 (largest swelling)			
Operation-target frequency	A141	Operation-target frequency selection 1	00 (digital operator), 01 (keypad potentiometer), 02 (input via O), 03 (input via OI), 04 (external communication), 05 (option 1), 06 (option 2), 07 (pulse-string frequency input)			
	A142	Operation-target frequency selection 2	00 (digital operator), 01 (keypad potentiometer), 02 (input via O), 03 (input via OI), 04 (external communication), 05 (option 1), 06 (option 2), 07 (pulse-string frequency input)			
	A143	Operator selection	00 (addition: A141 + A142), 01 (subtraction: A141 - A142), 02 (multiplication: A141 x A142)			
	A145	Frequency to be added	0.00 to 99.99, 100.0 to 400.0 (Hz)			
	A146	Sign of the frequency to be added	00 (frequency command + A145), 01 (frequency command - A145)			
Acceleration and deceleration	A150	EL-S-curve acceleration ratio 1	0. to 50. (%)			
	A151	EL-S-curve acceleration ratio 2	0. to 50. (%)			
	A152	EL-S-curve deceleration ratio 1	0. to 50. (%)			
	A153	EL-S-curve deceleration ratio 2	0. to 50. (%)			

Code	Function name	Monitored data or setting	Default			Note
			_FF	_FEF	_FUF	
Restart after instantaneous power failure or tripping	b001	Selection of restart mode	00 (tripping), 01 (starting with 0 Hz), 02 (starting with matching frequency), 03 (tripping after deceleration and stopping with matching frequency), 04 (restarting with active matching frequency)			00
	b002	Allowable under-voltage power failure time	0.3 to 25.0 (s)			1.0
	b003	Retry wait time before motor restart	0.3 to 100.0 (s)			1.0
	b004	Instantaneous power failure/under-voltage trip alarm enable	00 (disabling), 01 (enabling), 02 (disabling during stopping and decelerating to stop)			00
	b005	Number of restarts on power failure/under-voltage trip events	00 (16 times), 01 (unlimited)			00
	b006	Phase loss detection enable	00 (disabling), 01 (enabling)			00
	b007	Restart frequency threshold	0.00 to 99.99, 100.0 to 400.0 (Hz)			0.00
	b008	Selection of retry after tripping	00 (tripping), 01 (starting with 0 Hz), 02 (starting with matching frequency), 03 (tripping after deceleration and stopping with matching frequency), 04 (restarting with active matching frequency)			00
	b009	Selection of retry after undervoltage	00 (16 times), 01 (unlimited)			00
	b010	Selection of retry count after overvoltage or overcurrent	1 to 3 (times)			3
	b011	Retry wait time after tripping	0.3 to 100.0 (s)			1.0
Electronic thermal function	b012	Electronic thermal setting (calculated within the inverter from current output)	0.20 x "rated current" to 1.00 x "rated current" (A)			Rated current of inverter
	b212	Electronic thermal setting (calculated within the inverter from current output), 2nd motor	0.20 x "rated current" to 1.00 x "rated current" (A)			Rated current of inverter
	b312	Electronic thermal setting (calculated within the inverter from current output), 3rd motor	0.20 x "rated current" to 1.00 x "rated current" (A)			Rated current of inverter
	b013	Electronic thermal characteristic	00 (reduced-torque characteristic), 01 (constant-torque characteristic), 02 (free setting)			00 01 01
	b213	Electronic thermal characteristic, 2nd motor	00 (reduced-torque characteristic), 01 (constant-torque characteristic), 02 (free setting)			00 01 01
	b313	Electronic thermal characteristic, 3rd motor	00 (reduced-torque characteristic), 01 (constant-torque characteristic), 02 (free setting)			00 01 01
	b015	Free setting, electronic thermal frequency (1)	0. to 400. (Hz)			0.
	b016	Free setting, electronic thermal current (1)	0.0 to rated current (A)			0.0
	b017	Free setting, electronic thermal frequency (2)	0. to 400. (Hz)			0.
	b018	Free setting, electronic thermal current (2)	0.0 to rated current (A)			0.0
	b019	Free setting, electronic thermal frequency (3)	0. to 400. (Hz)			0.
b020	Free setting, electronic thermal current (3)	0.0 to rated current (A)			0.0	
Overload restriction and overcurrent restraint	b021	Overload restriction operation mode	00 (disabling), 01 (enabling during acceleration and deceleration), 02 (enabling during constant speed), 03 (enabling during acceleration and deceleration (increasing the speed during regeneration))			01
	b022	Overload restriction setting	0.20 x "rated current" to 1.00 x "rated current" (A)			Rated current of inverter x 1.50
	b023	Deceleration rate at overload restriction	0.10 to 30.00 (s)			1.00
	b024	Overload restriction operation mode (2)	00 (disabling), 01 (enabling during acceleration and deceleration), 02 (enabling during constant speed), 03 (enabling during acceleration and deceleration (increasing the speed during regeneration))			01
	b025	Overload restriction setting (2)	0.20 x "rated current" to 2.00 x "rated current" (A)			Rated current of inverter x 1.50
	b026	Deceleration rate at overload restriction (2)	0.10 to 30.00 (s)			1.00
	b027	Overcurrent suppression enable	00 (disabling), 01 (enabling)			01
	b028	Active frequency matching, scan start frequency	0.20 x "rated current" to 2.00 x "rated current" (A)			Rated current of inverter
	b029	Active frequency matching, scan-time constant	0.10 to 30.00 (s)			0.50
	b030	Active frequency matching, restart frequency select	00 (frequency at the last shutoff), 01 (maximum frequency), 02 (set frequency)			00
Software lock	b031	Software lock mode selection	00 (disabling change of data other than "b031" when SFT is on), 01 (disabling change of data other than "b031" and frequency settings when SFT is on), 02 (disabling change of data other than "b031"), 03 (disabling change of data other than "b031" and frequency settings), 10 (enabling data changes during operation)			01

Code	Function name	Monitored data or setting	Default			Note
			_FF	_FEF	_FUF	
Others	b034	Run/power-on warning time	0. to 9999. (0 to 99990), 1000 to 6553 (10000 to 655300) (hr)			0.
	b035	Rotational direction restriction	00 (enabling both forward and reverse rotations), 01 (enabling only forward rotation), 02 (enabling only reverse rotation)			00
	b036	Reduced voltage start selection	0 (minimum reduced voltage start time) to 255 (maximum reduced voltage start time)			6
	b037	Function code display restriction	00 (full display), 01 (function-specific display), 02 (user setting), 03 (data comparison display), 04 (basic display)			04
	b038	Initial-screen selection	00 (screen displayed when the STR key was pressed last), 01 (d001), 02 (d002), 03 (d003), 04 (d007), 05 (F001)			01
	b039	Automatic user-parameter setting function enable	00 (disabling), 01 (enabling)			00
Torque limitation	b040	Torque limit selection	00 (quadrant-specific setting), 01 (switching by terminal), 02 (analog input), 03 (option 1), 04 (option 2)			00
	b041	Torque limit (1) (forward-driving in 4-quadrant mode)	0. to 200. (%), no (disabling torque limitation)			150.
	b042	Torque limit (2) (reverse-regenerating in 4-quadrant mode)	0. to 200. (%), no (disabling torque limitation)			150.
	b043	Torque limit (3) (reverse-driving in 4-quadrant mode)	0. to 200. (%), no (disabling torque limitation)			150.
	b044	Torque limit (4) (forward-regenerating in 4-quadrant mode)	0. to 200. (%), no (disabling torque limitation)			150.
	b045	Torque limit LADSTOP enable	00 (disabling), 01 (enabling)			00
Non-stop operation at momentary power failure	b046	Reverse Run protection enable	00 (disabling), 01 (enabling)			00
	b050	Controller deceleration and stop on power loss	00 (disabling), 01 (nonstop deceleration to stop), 02 (DC voltage constant control, with resume), 03 (without resume)			00
	b051	DC bus voltage trigger level during power loss	0.0 to 999.9, 1000. (V)			220/440
	b052	Over-voltage threshold during power loss	0.0 to 999.9, 1000. (V)			360/720
	b053	Deceleration time setting during power loss	0.01 to 99.99, 100.0 to 999.9, 1000. to 3600. (s)			1.00
	b054	Initial output frequency decrease during power loss	0.00 to 10.00 (Hz)			0.00
	b055	Proportional gain setting for nonstop operation at power loss	0.00 to 2.55			0.20
b056	Integral time setting for nonstop operation at power loss	0.000 to 9.999 /10.00 to 65.53 (s)			0.100	
Window comparator	b060	Maximum-limit level of window comparators O	0. to 100. (lower limit : b061 + b062 / 2) (%)			100
	b061	Minimum-limit level of window comparators O	0. to 100. (lower limit : b060 - b062 / 2) (%)			0
	b062	Hysteresis width of window comparators O	0. to 10. (lower limit : b061 - b062 / 2) (%)			0
	b063	Maximum-limit level of window comparators OI	0. to 100. (lower limit : b064 + b066 / 2) (%)			100
	b064	Minimum-limit level of window comparators OI	0. to 100. (lower limit : b063 - b066 / 2) (%)			0
	b065	Hysteresis width of window comparators OI	0. to 10. (lower limit : b063 - b064 / 2) (%)			0
	b066	Maximum-limit level of window comparators OI	-100. to 100. (lower limit : b067 + b068 / 2) (%)			100
	b067	Minimum-limit level of window comparators O/OI/O2	-100. to 100. (lower limit : b066 - b068 / 2) (%)			0
	b068	Hysteresis width of window comparators O/OI/O2	0. to 10. (lower limit : b066 - b067 / 2) (%)			0
	b070	Operation level at O disconnection	0. to 100. (%) or "no" (ignore)			no
	b071	Operation level at OI disconnection	0. to 100. (%) or "no" (ignore)			no
b072	Operation level at O2 disconnection	-100. to 100. (%) or "no" (ignore)			no	

Code	Function name	Monitored data or setting	Default			Note		
			_FF	_FEE	_FUF			
Others	b078	Cumulative input power data clearance	Clearance by setting "01" and pressing the STR key			00		
	b079	Cumulative input power display gain setting	1. to 1000.			1.		
	b082	Start frequency adjustment	0.10 to 9.99 (Hz)			0.50		
	b083	Carrier frequency setting	0.5 to 15.0 (kHz) (subject to derating)			5.0		
	b084	Initialization mode (parameters or trip history)	00 (clearing the trip history), 01 (initializing the data), 02 (clearing the trip history and initializing the data)			00		
	b085	Country code for initialization	00 (Japan), 01 (EU), 02 (U.S.A.)			00 01 02		
	b086	Frequency scaling conversion factor	0.1 to 99.0			1.0		
	b087	STOP key enable	00 (enabling), 01 (disabling), 02 (disabling only the function to stop)			00		
	b088	Restart mode after FRS	00 (starting with 0 Hz), 01 (starting with matching frequency), 02 (starting with active matching frequency)			00		
	b089	Automatic carrier frequency reduction	00: invalid, 01: valid			00		
	b090	Dynamic braking usage ratio	0.0 to 100.0 (%)			0.0		
	b091	Stop mode selection	00 (deceleration until stop), 01 (free-run stop)			00		
	b092	Cooling fan control	00 (always operating the fan), 01 (operating the fan only during inverter operation [including 5 minutes after power-on and power-off])			00		
	b095	Dynamic braking control	00 (disabling), 01 (enabling [disabling while the motor is topped]), 02 (enabling [enabling also while the motor is topped])			00		
	b096	Dynamic braking activation level	330 to 380, 660 to 760(V)			360/ 720		
	b098	Thermistor for thermal protection control	00 (disabling the thermistor), 01 (enabling the thermistor with PTC), 02 (enabling the thermistor with NTC)			00		
	b099	Thermal protection level setting	0. to 9999. (Ω)			3000.		
	Free setting of V/f characteristic	b100	Free-setting V/f frequency (1)	0. to "free-setting V/f frequency (2)" (Hz)			0.	
		b101	Free-setting V/f voltage (1)	0.0 to 800.0 (V)			0.0	
b102		Free-setting V/f frequency (2)	0. to "free-setting V/f frequency (3)" (Hz)			0.		
b103		Free-setting V/f voltage (2)	0.0 to 800.0 (V)			0.0		
b104		Free-setting V/f frequency (3)	0. to "free-setting V/f frequency (4)" (Hz)			0.		
b105		Free-setting V/f voltage (3)	0.0 to 800.0 (V)			0.0		
b106		Free-setting V/f frequency (4)	0. to "free-setting V/f frequency (5)" (Hz)			0.		
b107		Free-setting V/f voltage (4)	0.0 to 800.0 (V)			0.0		
b108		Free-setting V/f frequency (5)	0. to "free-setting V/f frequency (6)" (Hz)			0.		
b109		Free-setting V/f voltage (5)	0.0 to 800.0 (V)			0.0		
b110		Free-setting V/f frequency (6)	0. to "free-setting V/f frequency (7)" (Hz)			0.		
b111		Free-setting V/f voltage (6)	0.0 to 800.0 (V)			0.0		
b112		Free-setting V/f frequency (7)	0. to 400. (Hz)			0.		
b113		Free-setting V/f voltage (7)	0.0 to 800.0 (V)			0.0		
Others	b120	Brake Control Enable	00 (disabling), 01 (enabling)			00		
	b121	Brake Wait Time for Release	0.00 to 5.00 (s)			0.00		
	b122	Brake Wait Time for Acceleration	0.00 to 5.00 (s)			0.00		
	b123	Brake Wait Time for Stopping	0.00 to 5.00 (s)			0.00		
	b124	Brake Wait Time for Confirmation	0.00 to 5.00 (s)			0.00		
	b125	Brake Release Frequency Setting	0.00 to 99.99, 100.0 to 400.0 (Hz)			0.00		
	b126	Brake Release Current Setting	0.0 to 2.00 x "rated current"			Rated current of inverter		
	b127	Braking frequency	0.00 to 99.99, 100.0 to 400.0 (Hz)			0.00		
	b130	Overvoltage suppression enable	00 (disabling the restraint), 01 (controlled deceleration), 02 (enabling acceleration)			00		
	b131	Overvoltage suppression level	330 to 390 (V) (200 V class model), 660 to 780 (V) (400 V class model)			380/ 760		
	b132	Acceleration and deceleration rate at overvoltage suppression	0.10 to 30.00 (s)			1.00		
b133	Overvoltage suppression proportional gain	0.00 to 2.55			0.50			
b134	Overvoltage suppression Integral time	0.000 to 9.999 / 10.00 to 65.53 (s)			0.060			

Code	Function name	Monitored data or setting	Default			Note	
			_FF	_FEF	_FUF		
Intelligent input terminals	C001	Terminal [1] function (*2)	18 (*2)				
	C002	Terminal [2] function	16				
	C003	Terminal [3] function (*2)	06 (*2)				
	C004	Terminal [4] function	11				
	C005	Terminal [5] function	09				
	C006	Terminal [6] function	03	03	13		
	C007	Terminal [7] function	02				
	C008	Terminal [8] function	01 (RV: Reverse RUN), 02 (CF1: Multispeed 1 setting), 03 (CF2: Multispeed 2 setting), 04 (CF3: Multispeed 3 setting), 05 (CF4: Multispeed 4 setting), 06 (JG: Jogging), 07 (DB: external DC braking), 08 (SET: Set 2nd motor data), 09 (2CH: 2-stage acceleration/deceleration), 11 (FRS: free-run stop), 12 (EXT: external trip), 13 (USP: unattended start protection), 14: (CS: commercial power source enable), 15 (SFT: software lock), 16 (AT: analog input voltage/current select), 17 (SET3: 3rd motor control), 18 (RS: reset), 20 (STA: starting by 3-wire input), 21 (STP: stopping by 3-wire input), 22 (F/R: forward/reverse switching by 3-wire input), 23 (PID: PID disable), 24 (PIDC: PID reset), 26 (CAS: control gain setting), 27 (UP: remote control UP function), 28 (DWN: remote control DOWN function), 29 (DWN: remote control data clearing), 31 (OPE: forcible operation), 32 (SF1: multispeed bit 1), 33 (SF2: multispeed bit 2), 34 (SF3: multispeed bit 3), 35 (SF4: multispeed bit 4), 36 (SF5: multispeed bit 5), 37 (SF6: multispeed bit 6), 38 (SF7: multispeed bit 7), 39 (OLR: overload restriction selection), 40 (TL: torque limit enable), 41 (TRQ1: torque limit selection bit 1), 42 (TRQ2: torque limit selection bit 2), 43 (PPI: P/I mode selection), 44 (BOK: braking confirmation), 45 (ORT: orientation), 46 (LAC: LAD cancellation), 47 (PCLR: clearance of position deviation), 48 (STAT: pulse train position command input enable), 50 (ADD: trigger for frequency addition [A145]), 51 (F-TM: forcible-terminal operation), 52 (ATR: permission of torque command input), 53 (KHC: cumulative power clearance), 54 (SON: servo-on), 55 (FOC: forcing), 56 (MI1: general-purpose input 1), 57 (MI2: general-purpose input 2), 58 (MI3: general-purpose input 3), 59 (MI4: general-purpose input 4), 60 (MI5: general-purpose input 5), 61 (MI6: general-purpose input 6), 62 (MI7: general-purpose input 7), 63 (MI8: general-purpose input 8), 65 (AHD: analog command holding), 66 (CP1: multistage position settings selection 1), 67 (CP2: multistage position settings selection 2), 68 (CP3: multistage position settings selection 3), 69 (ORL: Zero-return limit function), 70 (ORG: Zero-return trigger function), 71 (FOT: forward drive stop), 72 (ROT: reverse drive stop), 73 (SPD: speed / position switching), 74 (PCNT: pulse counter), 75 (PCC: pulse counter clear), no (NO: no assignment)	01			
	C011	Terminal [1] active state	00 (NO) / 01 (NC)				
	C012	Terminal [2] active state	00 (NO) / 01 (NC)				
	C013	Terminal [3] active state	00 (NO) / 01 (NC)				
	C014	Terminal [4] active state	00 (NO) / 01 (NC)				
	C015	Terminal [5] active state	00 (NO) / 01 (NC)				
	C016	Terminal [6] active state	00 (NO) / 01 (NC)				
	C017	Terminal [7] active state	00 (NO) / 01 (NC)				
	C018	Terminal [8] active state	00 (NO) / 01 (NC)				
	C019	Terminal [FW] active state	00 (NO) / 01 (NC)				

Code	Function name	Monitored data or setting	Default			Note
			_FF	_FEF	_FUF	
Intelligent output terminals	C021	Terminal [11] function	01			
	C022	Terminal [12] function	00			
	C023	Terminal [13] function	03			
	C024	Terminal [14] function	07			
	C025	Terminal [15] function	40			
	C026	Alarm relay terminal function	05			
Analog monitoring	C027	[FM] signal selection	00			
	C028	[AM] signal selection	00			
	C029	[AMI] signal selection	00			
	C030	Digital current monitor reference value	Rated current of inverter			
Intelligent output terminals	C031	Terminal [11] active state	00 (NO) / 01 (NC)			
	C032	Terminal [12] active state	00 (NO) / 01 (NC)			
	C033	Terminal [13] active state	00 (NO) / 01 (NC)			
	C034	Terminal [14] active state	00 (NO) / 01 (NC)			
	C035	Terminal [15] active state	00 (NO) / 01 (NC)			
	C036	Alarm relay active state	00 (NO) / 01 (NC)			

Code	Function name	Monitored data or setting	Default			Note	
			_FF	_FEF	_FUF		
Levels and output terminal status	C038	Low-current indication signal output mode selection	00 (output during acceleration/deceleration and constant-speed operation), 01 (output only during constant-speed operation)			01	
	C039	Low-current indication signal detection level	0.0 to 2.00 x "rated current" (A)			Rated current of inverter	
	C040	Overload signal output mode	00 (output during acceleration/deceleration and constant-speed operation), 01 (output only during constant-speed operation)			01	
	C041	Overload level setting	0.0 to 2.00 x "rated current" (A)			Rated current of inverter	
	C042	Frequency arrival setting for accel.	0.00 to 99.99, 100.0 to 400.0 (Hz)			0.00	
	C043	Frequency arrival setting for decel.	0.00 to 99.99, 100.0 to 400.0 (Hz)			0.00	
	C044	PID deviation level setting	0.0 to 100.0 (%)			3.0	
	C045	Frequency arrival setting for acceleration (2)	0.00 to 99.99, 100.0 to 400.0 (Hz)			0.00	
	C046	Frequency arrival setting for deceleration (2)	0.00 to 99.99, 100.0 to 400.0 (Hz)			0.00	
	C052	Maximum PID feedback data	0.0 to 100.0 (%)			100.0	
	C053	Minimum PID feedback data	0.0 to 100.0 (%)			0.0	
	C055	Over-torque (forward-driving) level setting	0. to 200. (%)			100.	
	C056	Over-torque (reverse regenerating) level setting	0. to 200. (%)			100.	
	C057	Over-torque (reverse driving) level setting	0. to 200. (%)			100.	
	C058	Over-torque (forward regenerating) level setting	0. to 200. (%)			100.	
	C061	Electronic thermal warning level setting	0. to 100. (%)			80.	
C062	Alarm code output	00 (disabling), 01 (3 bits), 02 (4 bits)			00		
C063	Zero speed detection level	0.00 to 99.99, 100.0 (Hz)			0.00		
C064	Heat sink overheat warning level	0. to 200.0 (°C)			120.		
Communication function	C071	Communication speed selection	02 (loopback test), 03 (2,400 bps), 04 (4,800 bps), 05 (9,600 bps), 06 (19,200 bps)			04	
	C072	Node allocation	1. to 32.			1.	
	C073	Communication data length selection	7 (7 bits), 8 (8 bits)			7	
	C074	Communication parity selection	00 (no parity), 01 (even parity), 02 (odd parity)			00	
	C075	Communication stop bit selection	1 (1 bit), 2 (2 bits)			1	
	C076	Selection of the operation after communication error	00 (tripping), 01 (tripping after decelerating and stopping the motor), 02 (ignoring errors), 03 (stopping the motor after free-running), 04 (decelerating and stopping the motor)			02	
	C077	Communication timeout limit before tripping	0.00 to 99.99 (s)			0.00	
	C078	Communication wait time	0. to 1000. (ms)			0.	
	C079	Communication mode selection	00(ASCII), 01(Modbus-RTU)			00	
Adjustment	C081	[O] input span calibration	0. to 9999., 1000 to 6553(10000 to 65530)			Factory setting	
	C082	[O] input span calibration	0. to 9999., 1000 to 6553(10000 to 65530)			Factory setting	
	C083	[O2] input span calibration	0. to 9999., 1000 to 6553(10000 to 65530)			Factory setting	
	C085	Thermistor input tuning	0.0 to 999.9, 1000.			Factory setting	
	C091	Debug mode enable	(Do not change this parameter, which is intended for factory adjustment.)			00	
Others	C101	Up/Down memory mode selection	00 (not storing the frequency data), 01 (storing the frequency data)			00	
	C102	Reset mode selection	00 (resetting the trip when RS is on), 01 (resetting the trip when RS is off), 2 (enabling resetting only upon tripping [resetting when RS is on])			00	
	C103	Restart mode after reset	00 (starting with 0 Hz), 01 (starting with matching frequency), 02 (restarting with active matching frequency),03(resetting only trip)			00	
Meter adjustment	C105	FM gain adjustment	50. to 200. (%)			100.	
	C106	AM gain adjustment	50. to 200. (%)			100.	
	C107	AMI gain adjustment	50. to 200. (%)			100.	
	C109	AM bias adjustment	0. to 100. (%)			0.	
C110	AMI bias adjustment	0. to 100. (%)			20.		

	Code	Function name	Monitored data or setting	Default			Note
				_FF	_FEF	_FUF	
Terminal	C111	Overload setting (2)	0.0 to 2.00 x "rated current" (A)	Rated current of inverter			
Adjustment	C121	[O] input zero calibration	0. to 9999., 1000 to 6553 (10000 to 65530)	Factory setting			
	C122	[OI] input zero calibration	0. to 9999., 1000 to 6553 (10000 to 65530)	Factory setting			
	C123	[O2] input zero calibration	0. to 9999., 1000 to 6553 (10000 to 65530)	Factory setting			
Output terminal operation function	C130	Output 11 on-delay time	0.0 to 100.0 (s)	0.0			
	C131	Output 11 off-delay time	0.0 to 100.0 (s)	0.0			
	C132	Output 12 on-delay time	0.0 to 100.0 (s)	0.0			
	C133	Output 12 off-delay time	0.0 to 100.0 (s)	0.0			
	C134	Output 13 on-delay time	0.0 to 100.0 (s)	0.0			
	C135	Output 13 off-delay time	0.0 to 100.0 (s)	0.0			
	C136	Output 14 on-delay time	0.0 to 100.0 (s)	0.0			
	C137	Output 14 off-delay time	0.0 to 100.0 (s)	0.0			
	C138	Output 15 on-delay time	0.0 to 100.0 (s)	0.0			
	C139	Output 15 off-delay time	0.0 to 100.0 (s)	0.0			
	C140	Output RY on-delay time	0.0 to 100.0 (s)	0.0			
	C141	Output RY off-delay time	0.0 to 100.0 (s)	0.0			
	C142	Logical output signal 1 selection 1	Same as the settings of C021 to C026 (except those of LOG1 to LOG6)	00			
	C143	Logical output signal 1 selection 2	Same as the settings of C021 to C026 (except those of LOG1 to LOG6)	00			
	C144	Logical output signal 1 operator selection	00 (AND), 01 (OR), 02 (XOR)	00			
	C145	Logical output signal 2 selection 1	Same as the settings of C021 to C026 (except those of LOG1 to LOG6)	00			
	C146	Logical output signal 2 selection 2	Same as the settings of C021 to C026 (except those of LOG1 to LOG6)	00			
	C147	Logical output signal 2 operator selection	00 (AND), 01 (OR), 02 (XOR)	00			
	C148	Logical output signal 3 selection 1	Same as the settings of C021 to C026 (except those of LOG1 to LOG6)	00			
	C149	Logical output signal 3 selection 2	Same as the settings of C021 to C026 (except those of LOG1 to LOG6)	00			
	C150	Logical output signal 3 operator selection	00 (AND), 01 (OR), 02 (XOR)	00			
	C151	Logical output signal 4 selection 1	Same as the settings of C021 to C026 (except those of LOG1 to LOG6)	00			
	C152	Logical output signal 4 selection 2	Same as the settings of C021 to C026 (except those of LOG1 to LOG6)	00			
	C153	Logical output signal 4 operator selection	00 (AND), 01 (OR), 02 (XOR)	00			
	C154	Logical output signal 5 selection 1	Same as the settings of C021 to C026 (except those of LOG1 to LOG6)	00			
	C155	Logical output signal 5 selection 2	Same as the settings of C021 to C026 (except those of LOG1 to LOG6)	00			
	C156	Logical output signal 5 operator selection	00 (AND), 01 (OR), 02 (XOR)	00			
	C157	Logical output signal 6 selection 1	Same as the settings of C021 to C026 (except those of LOG1 to LOG6)	00			
	C158	Logical output signal 6 selection 2	Same as the settings of C021 to C026 (except those of LOG1 to LOG6)	00			
C159	Logical output signal 6 operator selection	00 (AND), 01 (OR), 02 (XOR)	00				
Input terminal response	C160	Input terminal response time setting 1	0. to 200. (×2ms)	1			
	C161	Input terminal response time setting 2	0. to 200. (×2ms)	1			
	C162	Input terminal response time setting 3	0. to 200. (×2ms)	1			
	C163	Input terminal response time setting 4	0. to 200. (×2ms)	1			
	C164	Input terminal response time setting 5	0. to 200. (×2ms)	1			
	C165	Input terminal response time setting 6	0. to 200. (×2ms)	1			
	C166	Input terminal response time setting 7	0. to 200. (×2ms)	1			
	C167	Input terminal response time setting 8	0. to 200. (×2ms)	1			
	C168	Input terminal response time setting FW	0. to 200. (×2ms)	1			
Other	C169	Multistage speed/position determination time	0. to 200. (×10ms)	0			

Code	Function name	Monitored data or setting	Default			Note
			_FF	_FEF	_FUF	
Control constants	H001	Auto-tuning Setting	00 (disabling auto-tuning), 01 (auto-tuning without rotation), 02 (auto-tuning with rotation)			00
	H002	Motor data selection, 1st motor	00 (Hitachi standard data), 01 (auto-tuned data), 02 (auto-tuned data [with online auto-tuning function])			00
	H202	Motor data selection, 2nd motor	00 (Hitachi standard data), 01 (auto-tuned data), 02 (auto-tuned data [with online auto-tuning function])			00
	H003	Motor capacity, 1st motor	0.20 to 75.00 (kW)	Factory setting		
	H203	Motor capacity, 2nd motor	0.20 to 75.00 (kW)	Factory setting		
	H004	Motor poles setting, 1st motor	2, 4, 6, 8, 10 (poles)	4		
	H204	Motor poles setting, 2nd motor	2, 4, 6, 8, 10 (poles)	4		
	H005	Motor speed constant, 1st motor	0.001 to 9.999, 10.00 to 80.00 (10.000 to 80.000)	1.590		
	H205	Motor speed constant, 2nd motor	0.001 to 9.999, 10.00 to 80.00 (10.000 to 80.000)	1.590		
	H006	Motor stabilization constant, 1st motor	0. to 255.	100.		
	H206	Motor stabilization constant, 2nd motor	0. to 255.	100.		
	H306	Motor stabilization constant, 3rd motor	0. to 255.	100.		
	H020	Motor constant R1, 1st motor	0.001 to 9.999, 10.00 to 65.53 (Ω)	Depending on motor capacity		
	H220	Motor constant R1, 2nd motor	0.001 to 9.999, 10.00 to 65.53 (Ω)	Depending on motor capacity		
	H221	Motor constant R2, 1st motor	0.001 to 9.999, 10.00 to 65.53 (Ω)	Depending on motor capacity		
	H221	Motor constant R2, 2nd motor	0.001 to 9.999, 10.00 to 65.53 (Ω)	Depending on motor capacity		
	H222	Motor constant L, 1st motor	0.01 to 99.99, 100.0 to 655.3 (mH)	Depending on motor capacity		
	H222	Motor constant L, 2nd motor	0.01 to 99.99, 100.0 to 655.3 (mH)	Depending on motor capacity		
	H223	Motor constant I _o	0.01 to 99.99, 100.0 to 655.3 (A)	Depending on motor capacity		
	H223	Motor constant I _o , 2nd motor	0.01 to 99.99, 100.0 to 655.3 (A)	Depending on motor capacity		
	H224	Motor constant J	0.001 to 9.999, 10.00 to 99.99, 100.0 to 999.9, 1000. to 9999.	Depending on motor capacity		
	H224	Motor constant J, 2nd motor	0.001 to 9.999, 10.00 to 99.99, 100.0 to 999.9, 1000. to 9999.	Depending on motor capacity		
	H030	Auto constant R1, 1st motor	0.001 to 9.999, 10.00 to 65.53 (Ω)	Depending on motor capacity		
	H230	Auto constant R1, 2nd motor	0.001 to 9.999, 10.00 to 65.53 (Ω)	Depending on motor capacity		
	H231	Auto constant R2, 1st motor	0.001 to 9.999, 10.00 to 65.53 (Ω)	Depending on motor capacity		
	H231	Auto constant R2, 2nd motor	0.001 to 9.999, 10.00 to 65.53 (Ω)	Depending on motor capacity		
	H232	Auto constant L, 1st motor	0.01 to 99.99, 100.0 to 655.3 (mH)	Depending on motor capacity		
	H232	Auto constant L, 2nd motor	0.01 to 99.99, 100.0 to 655.3 (mH)	Depending on motor capacity		
	H233	Auto constant I _o , 1st motor	0.01 to 99.99, 100.0 to 655.3 (A)	Depending on motor capacity		
	H233	Auto constant I _o , 2nd motor	0.01 to 99.99, 100.0 to 655.3 (A)	Depending on motor capacity		
	H234	Auto constant J, 1st motor	0.001 to 9.999, 10.00 to 99.99, 100.0 to 999.9, 1000. to 9999.	Depending on motor capacity		
	H234	Auto constant J, 2nd motor	0.001 to 9.999, 10.00 to 99.99, 100.0 to 999.9, 1000. to 9999.	Depending on motor capacity		

Code	Function name	Monitored data or setting	Default			Note
			_FF	_FEF	_FUF	
Control constants	H050	PI proportional gain for 1st motor	0.0 to 999.9, 1000.			100.0
	H250	PI proportional gain for 2nd motor	0.0 to 999.9, 1000.			100.0
	H051	PI integral gain for 1st motor	0.0 to 999.9, 1000.			100.0
	H251	PI integral gain for 2nd motor	0.0 to 999.9, 1000.			100.0
	H052	P proportional gain setting for 1st motor	0.01 to 10.00			1.00
	H252	P proportional gain setting for 2nd motor	0.01 to 10.00			1.00
	H060	Zero LV limit for 1st motor	0.0 to 100.0			100.0
	H260	Zero LV limit for 2nd motor	0.0 to 100.0			100.0
	H061	Zero LV starting boost current for 1st motor	0. to 50. (%)			50.
	H261	Zero LV starting boost current for 2nd motor	0. to 50. (%)			50.
	H070	Terminal selection PI proportional gain setting	0.0 to 999.9, 1000.			100.0
	H071	Terminal selection PI integral gain setting	0.0 to 999.9, 1000.			100.0
	H072	Terminal selection P proportional gain setting	0.00 to 10.00			1.00
	H073	Gain switching time	0. to 9999. (ms)			100.

Code	Function name	Monitored data or setting	Default			Note
			_FF	_FEF	_FUF	
P001	Operation mode on expansion card 1 error	00 (tripping), 01 (continuing operation)	00			
P002	Operation mode on expansion card 2 error	00 (tripping), 01 (continuing operation)	00			
P011	Encoder pulse-per-revolution (PPR) setting	128. to 9999., 1000 to 6553(10000 to 65535) (pulses)	1024.			
P012	Control pulse setting	00 (ASR), 01 (APR), 02 (APR2), 03 (HAPR)	00			
P013	Pulse train mode setting	00 (mode 0), 01 (mode 1), 02 (mode 2)	00			
P014	Home search stop position setting	0. to 4095.	0.			
P015	Home search speed setting	"start frequency" to "maximum frequency" (up to 120.0) (Hz)	5.00			
P016	Home search direction setting	00 (forward), 01 (reverse)	00			
P017	Home search completion range setting	0. to 9999., 1000 (10000) (pulses)	5.			
P018	Home search completion delay time setting	0.00 to 9.99 (s)	0.00			
P019	Electronic gear set position selection	00 (feedback side), 01 (commanding side)	00			
P020	Electronic gear ratio numerator setting	0. to 9999.	1.			
P021	Electronic gear ratio denominator setting	0. to 9999.	1.			
P022	Feed-forward gain setting	0.00 to 99.99, 100.0 to 655.3	0.00			
P023	Position loop gain setting	0.00 to 99.99, 100.0	0.50			
P024	Position bias setting	-204 (-2048.) / -999. to 2048.	0.			
P025	Temperature compensation thermistor enable	00 (no compensation), 01 (compensation)	00			
P026	Over-speed error detection level setting	0.0 to 150.0 (%)	135.0			
P027	Speed deviation error detection level setting	0.00 to 99.99, 100.0 to 120.0 (Hz)	7.50			
P028	Numerator of motor gear ratio	0. to 9999.	1.			
P029	Denominator of motor gear ratio	0. to 9999.	1.			
P031	Accel/decel time input selection	00 (digital operator), 01 (option 1), 02 (option 2), 03 (easy sequence)	00			
P032	Positioning command input selection	00 (digital operator), 01 (option 1), 02 (option 2)	00			
P033	Torque command input selection	00 (O terminal), 01 (OI terminal), 02 (O2 terminal), 03 (digital operator)	00			
P034	Torque command setting	0. to 200. (%)	0.			
P035	Polarity selection at the torque command input via O2 terminal	00 (as indicated by the sign), 01 (depending on the operation direction)	00			
P036	Torque bias mode	00 (disabling the mode), 01 (digital operator), 02 (input via O2 terminal)	00			
P037	Torque bias value	-200. to +200. (%)	0.			
P038	Torque bias polarity selection	00 (as indicated by the sign), 01 (depending on the operation direction)	00			
P039	Speed limit for torque-controlled operation (forward rotation)	0.00 to "maximum frequency" (Hz)	0.00			
P040	Speed limit for torque-controlled operation (reverse rotation)	0.00 to "maximum frequency" (Hz)	0.00			
P044	DeviceNet comm watchdog timer	0.00 to 99.99 (s)	1.00			
P045	Inverter action on DeviceNet comm error	00 (tripping), 01 (tripping after decelerating and stopping the motor), 02 (ignoring errors), 03 (stopping the motor after free-running), 04 (decelerating and stopping the motor)	01			
P046	DeviceNet polled I/O: Output instance number	20, 21, 100	21			
P047	DeviceNet polled I/O: Input instance number	70, 71, 101	71			
P048	Inverter action on DeviceNet idle mode	00 (tripping), 01 (tripping after decelerating and stopping the motor), 02 (ignoring errors), 03 (stopping the motor after free-running), 04 (decelerating and stopping the motor)	01			
P049	DeviceNet motor poles setting for RPM	0, 2, 4, 6, 8, 10, 12, 14, 16, 18, 20, 22, 24, 26, 28, 30, 32, 34, 36, 38 (poles)	0			
P055	Pulse-string frequency scale	1.0 to 50.0 (kHz)	25.0			
P056	Time constant of pulse-string frequency filter	0.01 to 2.00 (s)	0.10			
P057	Pulse-string frequency bias	-100. to +100. (%)	0.			
P058	Pulse-string frequency limit	0. to 100. (%)	100.			

Optional functions

Code	Function name	Monitored data or setting	Default			Note
			_FF	_FEF	_FUF	
Absolute position control	P060	Multistage position setting 0	Position setting range reverse side to forward side (upper 4 digits including "-")			0
	P061	Multistage position setting 1	Position setting range reverse side to forward side (upper 4 digits including "-")			0
	P062	Multistage position setting 2	Position setting range reverse side to forward side (upper 4 digits including "-")			0
	P063	Multistage position setting 3	Position setting range reverse side to forward side (upper 4 digits including "-")			0
	P064	Multistage position setting 4	Position setting range reverse side to forward side (upper 4 digits including "-")			0
	P065	Multistage position setting 5	Position setting range reverse side to forward side (upper 4 digits including "-")			0
	P066	Multistage position setting 6	Position setting range reverse side to forward side (upper 4 digits including "-")			0
	P067	Multistage position setting 7	Position setting range reverse side to forward side (upper 4 digits including "-")			0
	P068	Zero-return mode selection	00(Low) / 01 (Hi1) / 00 (Hi2)	00		
	P069	Zero-return direction selection	00 (FW) / 01 (RV)	00		
	P070	Low-speed zero-return frequency	0.00 to 10.00 (Hz)	0.00		
	P071	High-speed zero-return frequency	0.00 to 99.99 / 100.0 to Maximum frequency setting, 1 st motor (Hz)	0.00		
	P072	Position range specification (forward)	0 to 268435455 (when P012 = 02) 0 to 1073741823 (when P012 = 03) (upper 4 digits)	268435455		
	P073	Position range specification (reverse)	-268435455 to 0 (when P012 = 02) -1073741823 to 0 (when P012 = 03) (upper 4 digits)	-268435455		
P074	Teaching selection	00 (X00) / 01 (X01) / 02 (X02) / 03 (X03) / 04 (X04) / 05 (X05) / 06 (X06) / 07 (X07) /	00			
Easy sequence function	P100	Easy sequence user parameter U (00)	0. to 9999., 1000 to 6553 (10000 to 65535)			0.
	P101	Easy sequence user parameter U (01)	0. to 9999., 1000 to 6553 (10000 to 65535)			0.
	P102	Easy sequence user parameter U (02)	0. to 9999., 1000 to 6553 (10000 to 65535)			0.
	P103	Easy sequence user parameter U (03)	0. to 9999., 1000 to 6553 (10000 to 65535)			0.
	P104	Easy sequence user parameter U (04)	0. to 9999., 1000 to 6553 (10000 to 65535)			0.
	P105	Easy sequence user parameter U (05)	0. to 9999., 1000 to 6553 (10000 to 65535)			0.
	P106	Easy sequence user parameter U (06)	0. to 9999., 1000 to 6553 (10000 to 65535)			0.
	P107	Easy sequence user parameter U (07)	0. to 9999., 1000 to 6553 (10000 to 65535)			0.
	P108	Easy sequence user parameter U (08)	0. to 9999., 1000 to 6553 (10000 to 65535)			0.
	P109	Easy sequence user parameter U (09)	0. to 9999., 1000 to 6553 (10000 to 65535)			0.
	P110	Easy sequence user parameter U (10)	0. to 9999., 1000 to 6553 (10000 to 65535)			0.
	P111	Easy sequence user parameter U (11)	0. to 9999., 1000 to 6553 (10000 to 65535)			0.
	P112	Easy sequence user parameter U (12)	0. to 9999., 1000 to 6553 (10000 to 65535)			0.
	P113	Easy sequence user parameter U (13)	0. to 9999., 1000 to 6553 (10000 to 65535)			0.
	P114	Easy sequence user parameter U (14)	0. to 9999., 1000 to 6553 (10000 to 65535)			0.
P115	Easy sequence user parameter U (15)	0. to 9999., 1000 to 6553 (10000 to 65535)			0.	

Code	Function name	Monitored data or setting	Default			Note	
			_FF	_FEF	_FUF		
Easy sequence function	P116	Easy sequence user parameter U (16)	0. to 9999., 1000 to 6553 (10000 to 65535)			0.	
	P117	Easy sequence user parameter U (17)	0. to 9999., 1000 to 6553 (10000 to 65535)			0.	
	P118	Easy sequence user parameter U (18)	0. to 9999., 1000 to 6553 (10000 to 65535)			0.	
	P119	Easy sequence user parameter U (19)	0. to 9999., 1000 to 6553 (10000 to 65535)			0.	
	P120	Easy sequence user parameter U (20)	0. to 9999., 1000 to 6553 (10000 to 65535)			0.	
	P121	Easy sequence user parameter U (21)	0. to 9999., 1000 to 6553 (10000 to 65535)			0.	
	P122	Easy sequence user parameter U (22)	0. to 9999., 1000 to 6553 (10000 to 65535)			0.	
	P123	Easy sequence user parameter U (23)	0. to 9999., 1000 to 6553 (10000 to 65535)			0.	
	P124	Easy sequence user parameter U (24)	0. to 9999., 1000 to 6553 (10000 to 65535)			0.	
	P125	Easy sequence user parameter U (25)	0. to 9999., 1000 to 6553 (10000 to 65535)			0.	
	P126	Easy sequence user parameter U (26)	0. to 9999., 1000 to 6553 (10000 to 65535)			0.	
	P127	Easy sequence user parameter U (27)	0. to 9999., 1000 to 6553 (10000 to 65535)			0.	
	P128	Easy sequence user parameter U (28)	0. to 9999., 1000 to 6553 (10000 to 65535)			0.	
	P129	Easy sequence user parameter U (29)	0. to 9999., 1000 to 6553 (10000 to 65535)			0.	
	P130	Easy sequence user parameter U (30)	0. to 9999., 1000 to 6553 (10000 to 65535)			0.	
P131	Easy sequence user parameter U (31)	0. to 9999., 1000 to 6553 (10000 to 65535)			0.		

Code	Function name	Monitored data or setting	Default			Note	
			_FF	_FEF	_FUF		
User parameters	U001	User-selected function 1	no/d001 to P131	no			
	U002	User-selected function 2	no/d001 to P131	no			
	U003	User-selected function 3	no/d001 to P131	no			
	U004	User-selected function 4	no/d001 to P131	no			
	U005	User-selected function 5	no/d001 to P131	no			
	U006	User-selected function 6	no/d001 to P131	no			
	U007	User-selected function 7	no/d001 to P131	no			
	U008	User-selected function 8	no/d001 to P131	no			
	U009	User-selected function 9	no/d001 to P131	no			
	U010	User-selected function 10	no/d001 to P131	no			
	U011	User-selected function 11	no/d001 to P131	no			
	U012	User-selected function 12	no/d001 to P131	no			

1.3 Code display system and key operations

This section describes typical examples of digital operator operation (in basic and full display modes) and an example of special digital operator operation in extended function mode U.

The initial display on the monitor screen after power-on depends on the setting of function "b038". For details, see Section 4.2.81, "Initial-screen selection," (on page 4-76).
 When the setting of function "b038" is "01" (factory setting), the monitor initially shows 0.00 as the setting of function "d001" (output frequency monitoring). Pressing the  key in this status changes the display to d001.



Note: The display contents on the monitor depend on the settings of functions "b037" (function code display restriction), "b038" (initial-screen selection), and "b039" (automatic setting of user parameters). For details, see Sections 4.2.80, "Function code display restriction," (on page 4-74), 4.2.81, "Initial-screen selection," (on page 4-76), and 4.2.82, "Automatic user-parameter setting," (on page 4-77).

Item	Function code	Data	Description
Function code display restriction	b037	00	Full display
		01	Function-specific display
		02	User setting
		03	Data comparison display
		04	Basic display (factory setting)
Initial-screen selection (Initial display at power-on)	b038 (*1)	00	Screen displayed when the [STR] key was pressed last (same as the operation on the SJ300 series)
		01	d001 (output frequency monitoring)
		02	d002 (output current monitoring)
		03	d003 (rotation direction monitoring)
		04	d007 (Scaled output frequency monitoring)
Selection of automatic user-parameter settings	b039 (*1)	00	Disable
		01	Enable

*1 Not displayed with the factory setting

* The following procedure enables you to turn the monitor display back to d001 or 0.00 (*1) regardless of the current display mode:

- Hold down the  key for 3 seconds or more. The monitor shows d001 and 0.00 (*1) alternately.

During this status, press the  key. The monitor will show only d001 or 0.00 (*1), which is shown when the  is pressed.

*1 The monitor shows 0.00 only when the motor driven by the inverter is stopped. While the motor is running, the monitor shows an output frequency.

1.3.1 Example of operation in basic display mode ("b037" = "04" [factory setting])

- Only basic parameters can be displayed in basic display mode. (All parameters in monitor mode, four parameters in function mode, or 20 parameters in extended function mode)
- Other parameters are not displayed. To display all parameters, select the full display mode ("b037" = "00").

<Displayable parameters and sequence of display>

No.	Display code	Item
1	d001 to d104	Monitor display
2	F001	Output frequency setting
3	F002	Acceleration (1) time setting
4	F003	Deceleration (1) time setting
5	F004	Operation direction setting
6	A001	Frequency source setting
7	A002	Run command source setting
8	A003	Base frequency setting
9	A004	Maximum frequency setting
10	A005	[AT] selection
11	A020	Multispeed frequency setting
12	A021	Multispeed 1 setting
13	A022	Multispeed 2 setting
14	A023	Multispeed 3 setting
15	A044	1st control method
16	A045	V/f gain setting
17	A085	Operation mode selection
18	b001	Selection of restart mode
19	b002	Allowable under-voltage power failure time
20	b008	Retry-after-trip selection
21	b011	Retry wait time after trip
22	b037	Function code display restriction
23	b083	Carrier frequency setting
24	b084	Initialization mode selection
25	b130	Selection of overvoltage suppression function
26	b131	Setting of overvoltage suppression level
27	C021	Setting of intelligent output terminal 11
28	C022	Setting of intelligent output terminal 12
29	C036	Alarm relay active state

Note:

If a desired parameter is not displayed, check the setting of function "b037" (function code display restriction). To display all parameters, specify "00" for "b037".

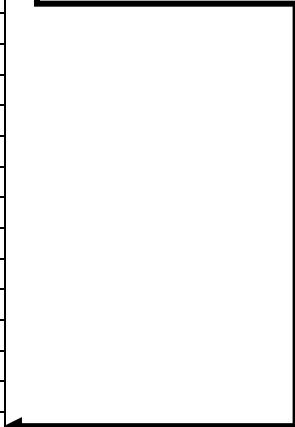

Key operation and transition of the codes on display

Key operation and transition of the monitored data on display

Pressing the \uparrow or \downarrow key respectively scrolls up or down the code displayed in code display mode or increases or decreases the numerical data displayed in data display mode.

Press the \uparrow or \downarrow key until the desired code or numerical data is shown. To scroll codes or increase/decrease numerical data faster, press and hold the key.

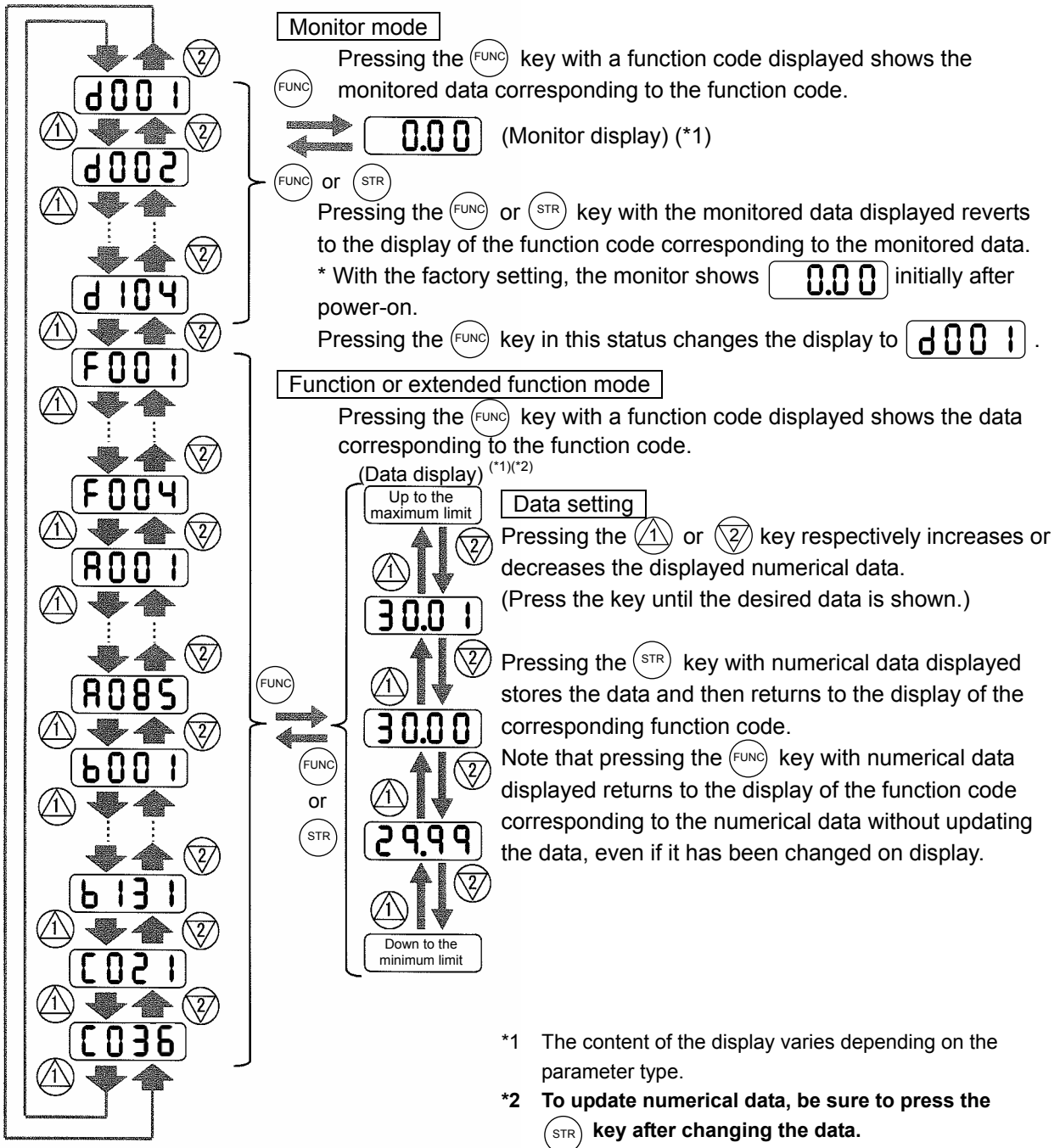

1.3.2 Example of operation in full display mode ("b037" = "00")

All parameters can be displayed in full display mode. The display sequence of parameters matches their sequence shown in Chapter 8, "List of Data Settings."

Key operation and transition of codes on display (in monitor or function mode)	Key operation and transition of monitored data on display (in monitor or function mode)	Key operation and transition of codes on display (in extended function mode)	Key operation and transition of monitored data on display (in extended function mode)
--	---	--	---

Pressing the Δ or ∇ key respectively scrolls up or down the code displayed in code display mode or increases or decreases the numerical data displayed in data display mode.

Press the Δ or ∇ key until the desired code or numerical data is shown. To scroll codes or increase/decrease numerical data fast, press and hold the key.

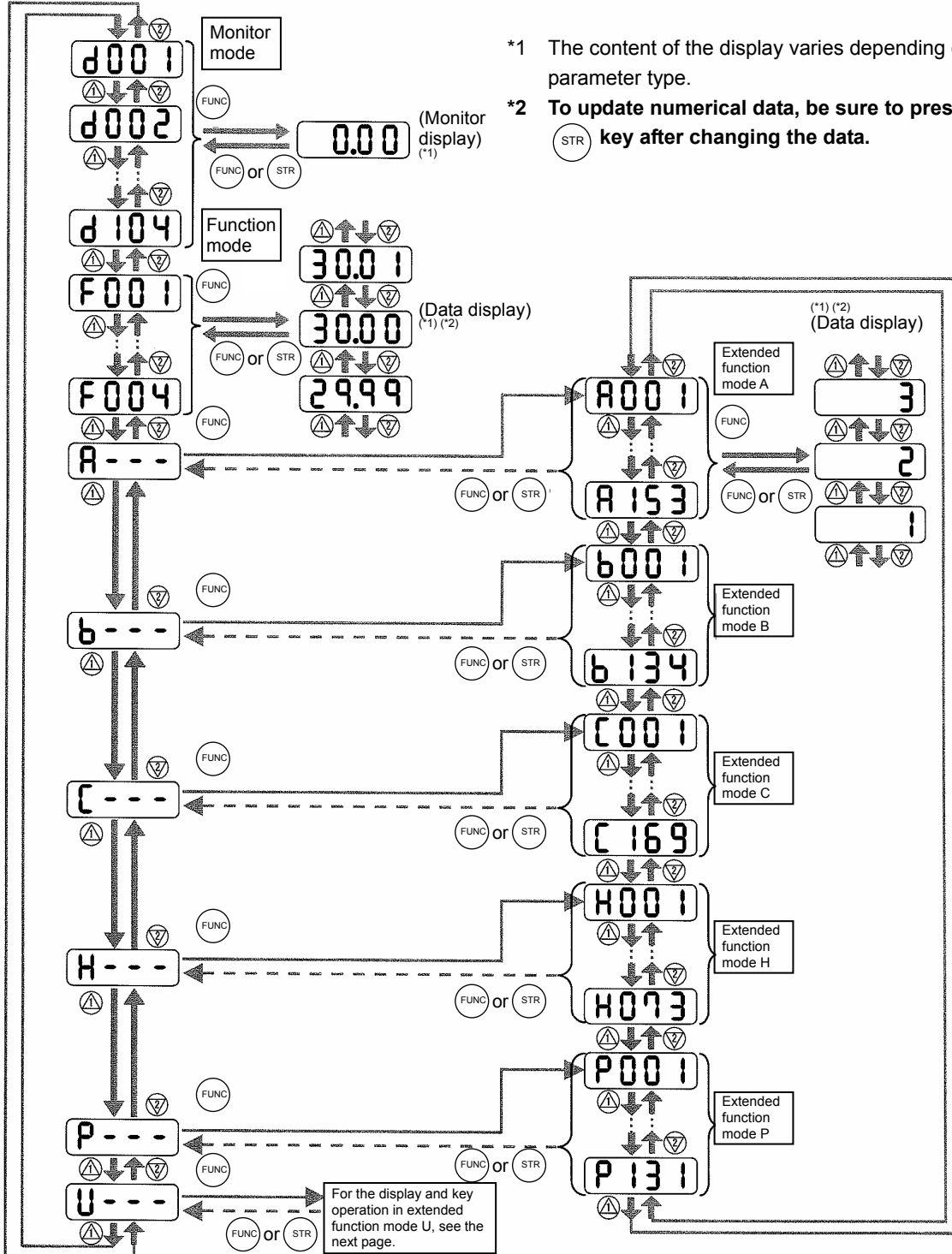

*1 The content of the display varies depending on the parameter type.

*2 To update numerical data, be sure to press the STR key after changing the data.

1.3.3 Code/data display and key operation in extended function mode U

The extended function mode U differs in operation from other extended function modes because the extended function mode U is used to register (or automatically record) other extended-function codes as user-specified U parameters.

Key operation and transition of codes on display (in monitor or function mode)	Key operation and transition of codes on display (in extended function mode U)	Key operation and transition of codes on display (when displaying extended-function mode parameters from the extended function mode U)	Key operation and transition of codes on display (in monitor, function, or extended
--	--	--	---





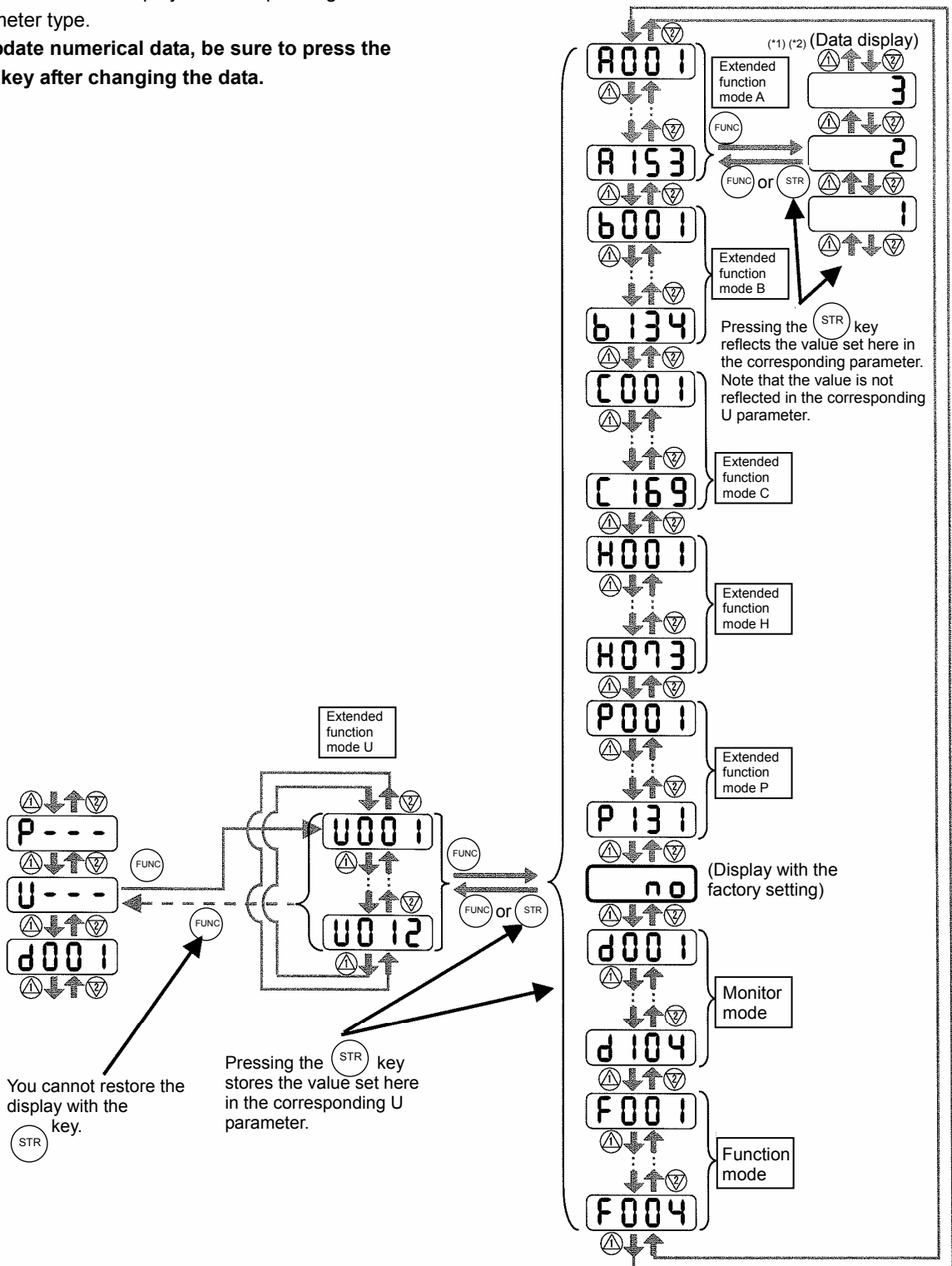



*1 The content of the display varies depending on the parameter type.

*2 To update numerical data, be sure to press the **STR** key after changing the data.



2. Troubleshooting











2.1 Inverter trip contents, remedy, advise

Name	Description	Display on digital operator	Display on remote operator	Troubleshooting and corrective action	
Overcurrent protection	If the motor is constrained or suddenly accelerated or decelerated, a high current will flow in the inverter and the inverter may fail. To avoid this problem, the inverter shuts off its output and displays the error code shown on the right when it detects a current higher than a specified level. This protective function uses a DC current detector (CT) to detect overcurrent. When a current as high as about 220% of the inverter's rated output current is detected, the protective circuit operates and the inverter trips.	During constant-speed operation		OC.Drive	Check whether the load has fluctuated sharply. (Eliminate the load fluctuation.) Check for the short circuit of output connections. (Check the output cables.) Check for the ground fault. (Check the output cables and motor.)
		During deceleration		OC.Decel	Check whether the inverter has decelerated the motor quickly. (Increase the deceleration time.)
		During acceleration		OC.Accel	Check whether the inverter has accelerated the motor quickly. (Increase the acceleration time.) Check whether the motor has been locked. (Check the motor and wiring.) Check whether the torque boost current has been set too high. (Reduce the boost current.)
		Others		Over.C	Check whether the DC braking force is too high. (Reduce the braking force.) Check whether the current detector (CT) is normal. (Replace or repair the CT.)
Overload protection (*1)	This protective function monitors the inverter output current, and shuts off the inverter output and displays the error code shown on the right when the internal electronic thermal protection circuit detects a motor overload. If the error occurs, the inverter will trip according to the setting of the electronic thermal function.		Over.L	Check whether the motor load is too high. (Reduce the load factor.) Check whether the thermal level is appropriate. (Adjust the level appropriately.) Note: The electronic thermal protection is easily triggered when the output frequency is 5 Hz or less. If the moment of inertia of the load is large, this protective function may operate when the inverter accelerates the motor and the acceleration may be disabled. If this problem occurs, increase the torque boost current or adjust other settings as needed.	
Braking resistor overload protection	When the BRD operation rate exceeds the setting of "b090", this protective function shuts off the inverter output and displays the error code shown on the right.		OL.BRD	Check whether the inverter has decreased the motor quickly. (Increase the deceleration time.) Check whether the operation cycle is too short. (Prolong the operation cycle.) Check whether the set BRD operation rate is too low. (Adjust the setting to an appropriate level.) Note: confirm the maximum allowable capacity of the resistor.	
Overvoltage protection	If the DC voltage across the P and N terminals rises too high, an inverter failure may result. To avoid this problem, this protective function shuts off the inverter output and displays the error code shown on the right when the DC voltage across the P and N terminals exceeds a specified level because of an increase in the energy regenerated by the motor or the input voltage (during operation). The inverter will trip if the DC voltage across the P and N terminals exceeds about 400 VDC (in case of the 200 V class models) or about 800 VDC (in case of the 400 V class models).		Over.V	Check whether the inverter has decreased the motor quickly. (Increase the deceleration time.) Check for a ground fault. (Check the output cables and motor.) Check whether the motor has been rotated by the action of the load. (Reduce the regenerative energy.)	
EEPROM error (*2) (*3)	When an internal-EEPROM is caused by external noise or an abnormal temperature rise, the inverter shuts off its output and displays the error code shown on the right. Note: An EEPROM error may result in a CPU error.		EEPROM	Check for the noise sources located near the inverter. (Remove noise sources.) Check whether the cooling efficiency has deteriorated. (Check the heat sink for clogging, and clean it.) (Replace the cooling fan.)	









*1 The inverter will not accept any reset command within about 10 seconds after tripping (i.e., after the protective function operates).

*2 The inverter will not accept any reset command after an EEPROM error occurs with error code  displayed. Turn off the inverter power once. If error code "E08" is displayed when the inverter power is turned on subsequently, the internal memory device may have failed or parameters may have not been stored correctly. In such cases, initialize the inverter, and then re-set the parameters.

*3 The inverter will not accept reset commands input via the RS terminal or entered by the STOP/RESET key. Therefore, turn off the inverter power.

Name	Description	Display on digital operator	Display on remote operator	Troubleshooting and corrective action
Undervoltage	If the inverter input voltage drops, the control circuit of the inverter cannot function normally. Therefore, the inverter shuts off its output when the input voltage falls below a specified level. The inverter will trip if the DC voltage across the P and N terminals exceeds about 175 VDC (in case of the 200 V class models) or about 345 VDC (in case of the 400 V class models).		Under.V	Check whether the power supply voltage has dropped. (Check the power supply.) Check whether the power supply capacity is sufficient. (Check the power supply.) Check whether the thyristor has been damaged. (Check the thyristor.)
CT error	If an error occurs in the internal current detector (CT), the inverter will shut off its output and display the error code shown on the right. The inverter will trip when the CT outputs about 0.6 V or more at power-on.		CT	Check whether the inverter has failed. (Repair the inverter.)
CPU error (*3)	If the internal CPU malfunctions or an error occurs in it, the inverter will shut off its output and display the error code shown on the right. Note: Reading an abnormal data from the EEPROM may result in a CPU error.		CPU	Check for the noise sources located near the inverter. (Remove noise sources.) Check whether the inverter has failed. (Repair the inverter.)
External trip	If an error occurs in the external equipment or device connected to the inverter, the inverter will fetch the error signal and shut off its output. (This protective function is enabled when the external trip function is enabled.)		EXTERNAL	Check whether an error has occurred in the external equipment (when the external trip function has been enabled). (Recover the external equipment from the error.)
USP error	A USP error is indicated when the inverter power is turned on with an input operation signal remaining in the inverter. (This protective function is enabled when the USP function is enabled.)		USP	Check whether the inverter power has been turned on with an input operation signal remaining in the inverter (when the USP function has been enabled). (Reset the operation command, and then turn on the inverter power.)
Ground-fault protection (*3)	When the inverter power is turned on, this protective function detects the ground fault between the inverter output circuit and the motor to protect the inverter. (This function does not operate when a residual voltage remains in the motor.)		GND.Flt	Check for the ground fault. (Check the output cables and motor.) Check the inverter itself for abnormality. (Remove the output cables from the inverter, and then check the inverter.) Check the main circuit for abnormality. (Check the main circuit with reference to Chapter 6.) (Repair the inverter.)
Input overvoltage protection	This protective function determines an error if the input voltage is kept above the specification level for 100 seconds while the inverter is stopped. The inverter will trip if the DC voltage of the main circuit is kept above about 390 VDC (in case of the 200 V class models) or about 780 VDC (in case of the 400 V class models).		OV.SRC	Check whether the input voltage is high while the inverter is stopped. (Lower the input voltage, suppress the power voltage fluctuation, or connect an AC reactor between the power supply and the inverter input.)
Instantaneous power failure protection	If an instantaneous power failure lasts 15 ms or more, the inverter will shut off its output. When the power failure duration is long, the inverter assumes a normal power-off. If a restart mode has been selected and an operation command remains in the inverter, the inverter will restart after the power is recovered.		Inst.P-F	Check whether the power supply voltage has dropped. (Recover the power supply.) Check the MCB and magnetic contactors for poor contacts. (Replace the MCB and the magnetic contactor.)
Temperature error due to low cooling-fan speed	The inverter will display the error code shown on the right if the lowering of cooling-fan speed is detected at the occurrence of the temperature error described below.		OH.stFAN	Check whether the cooling efficiency has been lowered. (Replace the cooling fan.) Check the heat sink for clogging. (Clean the heat sink.)
Temperature error	If the main circuit temperature rises because of a high ambient temperature or for other reasons, the inverter will shut off its output.		OH.fin	Check whether the inverter is installed vertically. (Check the installation.) Check whether the ambient temperature is high. (Lower the ambient temperature.)

*3 The inverter will not accept reset commands input via the RS terminal or entered by the STOP/RESET key. Therefore, turn off the inverter power.

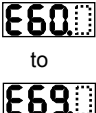
Name	Description	Display on digital operator	Display on remote operator	Troubleshooting and corrective action
Gate array communication error	If an error occurs in the communication between the internal CPU and gate array, the inverter will trip.		GA.COM	Check for the noise sources located near the inverter. (Remove noise sources.) Check whether the communication cable has been disconnected. (Check the connectors.)
Phase loss input protection	When the phase loss input protection has been enabled (b006 = 01), the inverter will trip to avoid damage if an phase loss input is detected. The inverter trips when the phase loss input continues for about 1 second or more.		PH.fail	Check for the phase loss power input. (Check the power supply input wiring.) Check the MCB and magnetic contactors for poor contacts. (Replace the MCB and magnetic contactors.)
Main circuit error (*3)	The inverter will trip if the gate array cannot confirm the on/off state of IGBT because of a malfunction due to noise, short or damage to the main circuit element.		Main.Cir	Check for the noise sources located near the inverter. (Remove noise sources.) Check the main circuit element for damage. Check the output circuit for a short circuit. (Check the IGBT.) Check the inverter for abnormality. (Repair the inverter.)
IGBT error	If instantaneous overcurrent occurs, the main circuit element temperature is abnormal, or the main circuit element drive power drops, the inverter will shut off its output to protect the main circuit element. (After tripping because of this protective function, the inverter cannot retry the operation.)		IGBT	Check the output circuit for a short circuit. (Check the output cables.) Check for the ground fault. (Check the output cables and motor.) Check the main circuit element for damage. (Check the IGBT.) Check the heat sink for clogging. (Clean the heat sink.)
Thermistor error	The inverter monitors the resistance of the thermistor (in the motor) connected to the inverter's TH terminal, and will shut off the inverter output if the motor temperature rises.		TH	Check whether the motor temperature is high. (Check the motor temperature.) Check whether the internal thermistor of the motor has been damaged. (Check the thermistor.) Check whether noise has been mixed in the thermistor signal. (Separate the thermistor wiring from other wirings.)
Braking error	When "01" has been specified for the Brake Control Enable (b120), the inverter will trip if it cannot receive the braking confirmation signal within the Brake Wait Time for Confirmation (b124) after the output of the brake release signal.		BRAKE	Check whether the brake has been turned on and off or not. (Check the brake.) Check whether the wait time (b124) is too short. (Increase the wait time [b124].) Check whether the braking confirmation signal has been input. (Check the wiring.)
Emergency stop (*4)	If the EMR signal (on three terminals) is turned on when the slide switch (SW1) on the logic board is set to ON, the inverter hardware will shut off the inverter output and display the error code shown on the right. Malfunction due to incoming noise, in case EMR terminal is not ON.		EMR	Check whether an error has occurred in the external equipment since the emergency stop function was enabled. (Recover the external equipment from the error.) Check for the noise sources located near the inverter. (Remove noise sources.)
Low-speed overload protection	If overload occurs during the motor operation at a very low speed at 0.2 Hz or less, the electronic thermal protection circuit in the inverter will detect the overload and shut off the inverter output. (2nd electronic thermal control) (Note that a high frequency may be recorded as the error history data.)		OL-LowSP	Check whether the motor load is too high. (Reduce the load factor.)
Modbus communication error	If timeout occurs because of line disconnection during the communication in Modbus-RTU mode, the inverter will display the error code shown on the right. (The inverter will trip according to the setting of "C076".)		NET.ERR	Check whether the communication speed setting is correct. Check whether the wiring distance is appropriate. (Check the connections.)
Option 1 error	The inverter detects errors in the option board mounted in the optional slot 1. For details, refer to the instruction manual for the mounted option board.		OP1-0 OP1-9	Check whether the option board is mounted correctly. (Check the board mounting.) Check whether the option board is used correctly. (Check the instruction manual for the option board.)

*3 The inverter will not accept reset commands input via the RS terminal or entered by the STOP/RESET key. Therefore, turn off the inverter power.

*4 The inverter will not accept the reset command entered from the digital operator. Therefore, reset the inverter by turning on the RS terminal.

Name	Description	Display on digital operator	Display on remote operator	Troubleshooting and corrective action
Option 2 error	The inverter detects errors in the option board mounted in the optional slot 2. For details, refer to the instruction manual for the mounted option board.	E70 to E79	OP2-0 OP2-9	Check whether the option board is mounted correctly. (Check the board mounting.) Check whether the option board is used correctly. (Check the instruction manual for the option board.)
Waiting in undervoltage status	If the input voltage falls, the inverter will shut off its output, display the code shown on the right, and wait for the recovery of the input voltage. The inverter will display the same error code also during an instantaneous power failure. (remark) Inverter trips with under voltage when this status continues for 40 seconds.	— — — —	UV.WAIT	Check whether the power supply voltage has fallen. (Recover the power supply.) Check the MCB and magnetic contactors for poor contacts. (Replace the MCB and magnetic contactors.) Check whether the voltage across the P and N terminals is normal. (Check the voltage across the P and N terminals.)
Communication error	If a problem occurs in the communication between the digital operator and inverter, the inverter will display the code shown on the right.	— — — —	R-ERROR COMM<1> R-ERROR COMM<2>	Check whether the relay plug is fitted correctly. (Check the relay plug for connection.) Check whether the digital operator is connected correctly. (Check the digital operator for connection.)
Waiting for retry	When the retry after instantaneous power failure or tripping has been enabled, the inverter displays the code shown on the right while awaiting retry after an instantaneous power failure or tripping.	0000	RESTART ADJUST	
Power-off	The inverter displays the code shown on the right when the inverter power is turned off.	— — — —	POWER OFF	
Restricted operation command	When an operation direction has been restricted by the setting of "b035", the inverter will display the error code shown on the right if the operation command specifying the restricted operation direction is input.	0000	RUN.CMD DISABLE	
Empty trip history	If the inverter has not tripped before, the inverter displays — — — — .	— — — —	?	

2.2 Option boards error codes

When an option board is mounted in the optional port 1 (located near the operator connector), the error code display format is "E6*." (on the digital operator) or "OP1-*" (on the remote operator). When it is mounted in the optional port 2 (located near the control circuit terminal block), the error code display format is "E7*." (on the digital operator) or "OP2-*" (on the remote operator).

2.2.1 Error indications by protective functions with the feedback option board (SJ-FB) mounted

Name	Description	Display on digital operator	Display on remote operator ERR1***
Encoder disconnection	If the encoder wiring is disconnected, an encoder connection error is detected, the encoder fails, or an encoder that does not support line driver output is used, the inverter will shut off its output and display the error code shown on the right.	E60. E70.	OP1-0 OP2-0
Excessive speed	If the motor speed rises to "maximum frequency (A004) x over-speed error detection level (P026)" or more, the inverter will shut off its output and display the error code shown on the right.	E61. E71.	OP1-1 OP2-1
Positioning error	If, in position control mode, the deviation of the current position from that specified by the positioning command increases to 1,000,000 pulses or more, the inverter will shut off its output and display the error code shown on the right.	E62. E72.	OP1-2 OP2-2
Position control range trip	In absolute position control mode, the inverter shuts off its output and indicates an error when the range specified by the position range specification (forward) (P072) or position range specification (reverse) (P073) is exceeded.	E63. E73.	OP1-3 OP2-3
SJ-FB connection error	If a faulty connection (i.e., mounting) of the feedback option board is detected, the inverter will shut off its output and display the error code shown on the right.	E69. E79.	OP1-9 OP2-9





Note: If the option board does not operate normally, confirm the DIP switch settings on the option board.

Functions of the DIP switches on the feedback option board (SJ-FB)

DIP switch	Switch No.	Setting	
SWENC	1	ON	Enabling the detection of encoder disconnection when the encoder phases A and B are not connected
		OFF	Disabling the detection of encoder disconnection when the encoder phases A and B are not connected
	2	ON	Enabling the detection of encoder disconnection when the encoder phase Z is not connected
		OFF	Disabling the detection of encoder disconnection when the encoder phase Z is not connected
SWR	1	ON	Enabling the terminating resistor between the SAP and SAN terminals (150Ω)
		OFF	Disabling the terminating resistor between the SAP and SAN terminals
	2	ON	Enabling the terminating resistor between the SBP and SBN terminals (150Ω)
		OFF	Disabling the terminating resistor between the SBP and SBN terminals

Note: For details, refer to the instruction manual for the option board.

2.2.2 Error indications by protective functions with the digital option board (SJ-DG) mounted

Name	Description	Display on digital operator	Display on remote operator ERR1***
SJ-DG error	If timeout occurs during the communication between the inverter and digital option board, the inverter will shut off its output and display the error code shown on the right.	 	 

Note: The input mode is determined by a combination of DI switch and rotary switch settings. If the option board does not operate normally, confirm the DIP switch and rotary switch settings on the option board.

Functions of the DIP and rotary switches on the digital option board (SJ-DG)

DIP switch		Rotary switch	Frequency setting				Acceleration/ deceleration time setting			Torque limit setting	Position setting	
Type		Code	Data resolution									
Switch No.		Code for setting	0.01 Hz	0.1 Hz	1 Hz	Rate	0.01 sec	0.1 sec	1 sec	1%	1 pulse	
1	2											
OFF: BIN (binary input)/ ON: BCD (BCD input)	OFF: PAC (batch input mode)	0	<input type="radio"/>									
		1		<input type="radio"/>								
		2			<input type="radio"/>							
		3				<input type="radio"/>						
		4								<input type="radio"/>		
		5										
		6									<input type="radio"/>	
		0		<input type="radio"/>				<input type="radio"/>				
		1							<input type="radio"/>			
		2								<input type="radio"/>		
		3					<input type="radio"/>					
		4			<input type="radio"/>				<input type="radio"/>			
	5								<input type="radio"/>			
	6					<input type="radio"/>						
	7				<input type="radio"/>			<input type="radio"/>				
	8								<input type="radio"/>			
	9						<input type="radio"/>					
	A					<input type="radio"/>		<input type="radio"/>				
	B								<input type="radio"/>			

○: Input mode specified by switch settings

Note: For details, refer to the instruction manual for the option board.

2.2.3 Error indications by protective functions with the DeviceNet option board (SJ-DN) mounted

Name	Description	Display on digital operator	Display on remote operator	Troubleshooting and corrective action
DeviceNet communication error	If the disconnection due to the Bus-Off signal or timeout occurs during the operation using DeviceNet commands, the inverter will shut off its output and display the error code shown on the right. (The inverter will trip according to the settings of "p45" and "P048".)	E60 E70	OP1-0 OP2-0	Check whether the communication speed setting is correct. Check whether the wiring distance is appropriate. Check the connections.
Duplicate MAC ID	If two or more devices having the same MAC ID are detected in the same network, the inverter will display the error code shown on the right.	E61 E71	OP1-1 OP2-1	Check whether duplicate MAC IDs are used.
External trip	If the Force Fault/Trip bit of Attribute 17 in the Instance 1 of the Control Supervisory object is set to "1", the inverter will shut off its output and display the error code shown on the right.	E62 E72	OP1-2 OP2-2	Check whether the Attribute 17 in the Instance 1 of Class 29 is "1". (If so, clear the bit to "0".)
Inverter communication error	If timeout occurs during the communication between the inverter and DeviceNet option board, the inverter will shut off its output and display the error code shown on the right.	E69 E79	OP1-9 OP2-9	Check whether the option board has been disconnected from the inverter.

Note: If the option board does not operate normally, confirm the DIP switch settings on the option board.

Functions of the DIP switches on the DeviceNet option board (SJ-DN)

Setting of DeviceNet baud rate (DIP switches No. 1 and No. 2)

Baud rate	125 kbps	250 kbps	500 kbps
DIP switch setting			

Setting of MAC ID (DIP switches No. 3 to No. 8)

MAC ID	Dip switch setting
	<p>The left-most switch indicates the highest-order bit of MAC ID. Therefore, the example of switch settings shown on the left indicates the following MAC ID:</p> $1 \cdot 2^5 + 0 \cdot 2^4 + 1 \cdot 2^3 + 0 \cdot 2^2 + 0 \cdot 2^1 + 1 \cdot 2^0 = 29 \text{ (hexadecimal)} = 41 \text{ (decimal)}$ <p style="text-align: center;"> $\overline{NA32}$ $\overline{NA16}$ $\overline{NA8}$ $\overline{NA4}$ $\overline{NA2}$ $\overline{NA1}$ </p>

Note: For details, refer to the instruction manual for the option board.

2.2.4 Error indications by protective functions with the easy sequence function used

Name	Description	Display on digital operator	Display on remote operator ERR1***
Invalid instruction	<ul style="list-style-type: none"> - The inverter will display the error code shown on the right if an invalid instruction is found in a downloaded program. (*1) - The inverter will display the error code if the PRG terminal is turned on when no program has been loaded. 	E43	PRG.CMD
Nesting count error	The inverter will display the error code shown on the right if subroutines, "for" instructions, and "next" instructions are nested in more than eight levels.	E44	PRG.NST
Execution error 1	<ul style="list-style-type: none"> - The inverter will display the error code shown on the right if the "for" or another instruction to start nesting is not found at the jump destination of a "go to" instruction, and the "next" or another instruction to end nesting precedes the nesting-start instruction. - An error is assumed when an arithmetic operation instruction has resulted in overflow or underflow or a division by zero has been attempted. - An error is assumed when a "chg param" or "mon param" instruction has attempted to reference an undefined parameter, set the data beyond the specified setting range in a parameter, or update a parameter that cannot be changed during the inverter operation. 	E45	PRG.ERR1
User trips 0 to 9	The inverter outputs an error code when a trip instruction is executed.	E50 5 E59	PRG-0 PRG-9

*1 The error code is output when the relevant program runs.

2.3 Trip conditions monitoring

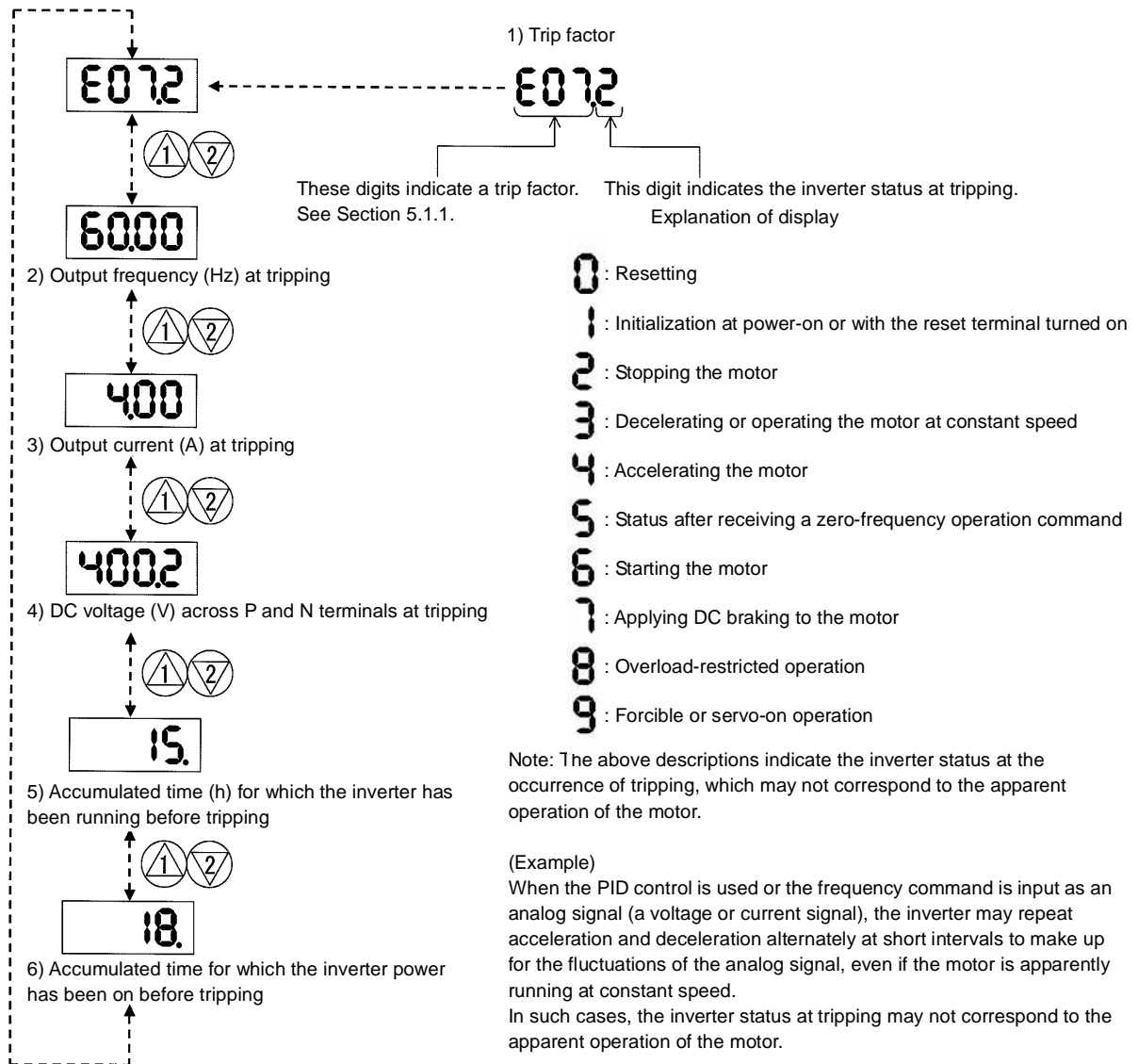

2.4 Warning Codes

The following table lists the warning codes and the contents of parameter readjustments:

Warning code	Target function code	Condition	Basic function code
001/201	Frequency upper limit setting (A061/A261)	>	Maximum frequency setting (A004/A204/A304)
002/202	Frequency lower limit setting (A062/A262)	>	
004/204/304	Base frequency setting (A003/A203/A303) (*1)	>	
005/205/305	Output frequency setting (F001), multispeed 0 (A202/A220/A320) (*2)	>	
006/206/306	Multispeed 1 to 15 settings (A021 to A035)	>	
009	Home search speed setting (P015)	>	
012/212	Frequency lower limit setting (A062/A262)	>	Frequency upper limit setting (A061/A261)
015/215	Output frequency setting (F001), multispeed 0 (A202/A220/A320) (*2)	>	
016/216	Multispeed 1 to 15 settings (A021 to A035)	>	
019	Frequency upper limit setting (A061/A261)	<	Home search speed setting (P015)
021/221		<	Frequency lower limit setting (A062/A262)
025/225	Output frequency setting (F001), multispeed 0 (A202/A220/A320) (*2)	<	
031/231	Frequency upper limit setting (A061/A261)	<	Start frequency adjustment (b082)
032/232	Frequency lower limit setting (A062/A262)	<	
035/235/335	Output frequency setting (F001), multispeed 0 (A202/A220/A320) (*2)	<	
036	Multispeed 1 to 15 settings (A021 to A035)	<	
037	Jog frequency setting (A038)	<	
085/285/385	Output frequency setting (F001), multispeed 0 (A202/A220/A320) (*2)	<>	Jump (center) frequency settings 1/2/3 ± " Jump (hysteresis) frequency width settings 1/2/3" A063 ± A064, A065 ± A066, A067 ± A068 (*3)
086	Multispeed 1 to 15 settings (A021 to A035)	<>	
091/291	Frequency upper limit setting (A061/A261)	>	Free-setting V/f frequency (7) (b112)
092/292	Frequency lower limit setting (A062/A262)	>	
095/295	Output frequency setting (F001), multispeed 0 (A202/A220/A320) (*2)	>	
096	Multispeed 1 to 15 settings (A021 to A035)	>	
110	Free-setting V/f frequency (1) to (6) (b100, b102, b104, b106, b108, b110)	>	Free-setting V/f frequency (1) (b100)
	Free-setting V/f frequency (2) to (6) (b102, b104, b106, b108, b110)	<	
	Free-setting V/f frequency (1) (b100)	>	
	Free-setting V/f frequency (3) to (6) (b104, b106, b108, b110)	<	
	Free-setting V/f frequency (1) (2) (b100, b102)	>	
	Free-setting V/f frequency (4) to (6) (b106, b108, b110)	<	
	Free-setting V/f frequency (1) to (3) (b100, b102, b104, b110)	>	
	Free-setting V/f frequency (5) (6) (b108, b110)	<	
	Free-setting V/f frequency (1) to (4) (b100, b102, b104, b106)	>	
Free-setting V/f frequency (6) (b110)	<		
120	Free setting, electronic thermal frequency (1) (2) (3) (b017/b019)	<	Free setting, electronic thermal frequency (1) (b015)
	Free setting, electronic thermal frequency (1) (b015)	>	Free setting, electronic thermal frequency (2) (b017)
	Free setting, electronic thermal frequency (3) (b019)	<	Free setting, electronic thermal frequency (3) (b019)
	Free setting, electronic thermal frequency (1) (2) (b015/b017)	>	Free setting, electronic thermal frequency (3) (b019)

The inverter displays a warning code when the data set as a target function code satisfies the condition (specified in the Condition column) in relation to the data set as the corresponding basic function code.

Each parameter (target function code) is readjusted to the data set as the basic function code (by updating at the inverter start-up).

*1 In this case, the base frequency is rewritten at parameter readjustment. If the base frequency is updated to an inappropriate value, a motor burnout may result. Therefore, if the warning is displayed, change the current base frequency data to an appropriate value.

*2 These parameters are checked, even when the digital operator (02) is not specified for the frequency source setting (A001).

*3 The current value of the jump (center) frequency is updated to "the current value of the jump frequency" - "value of the Jump (hysteresis) frequency width (minimum)".

2.5 Initialization setting

The initialization function allows you to initialize the adjusted settings on the inverter to restore the factory settings. You can also clear the trip history data alone.

The settings of initialization are described below.

The settings of "P100" to "P131", running-time data, and power-on time data cannot be cleared.

Item	Function code	Data	Description
Initialization mode (parameters or trip history)	b084	00	Clearing on the trip history data
		01	Initializing only the settings The factory settings are restored.
		02	Clearing the trip history data and initializing the settings
Country code for initialization	b085	00	Defaults intended for Japan
		01	Defaults intended for Europe
		02	Defaults intended for the U.S.A.

(Initializing procedure)

Adjust the above settings as required, and then perform the following procedure:

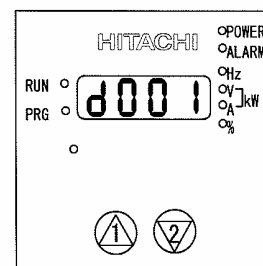
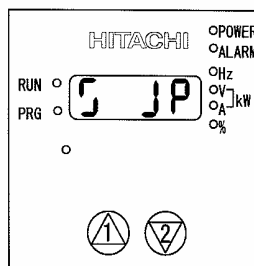
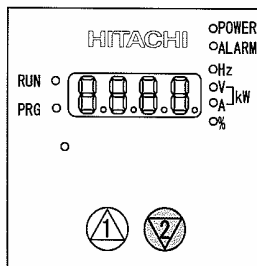

- 1) Holding down the FUNC and [2] (down) keys, press and hold down the STOP/RESET key.
 - After the monitor starts blinking, release only the STOP/RESET key. (The display on the monitor changes to that shown in the middle figure above.)
 - Release the FUNC and [2] (down) keys.

- 2) Initialization is in progress.
 - The above figure shows the monitor display (indicating that the initialization is in progress) intended for Japan. Those intended for other regions and trip history clearance are shown below.

- 3) When the initialization is completed, the monitor displays code "d001". Confirm that the settings have been initialized.

Initialization-in-progress display intended for Europe

Initialization-in-progress display intended for the U.S.A.

Initialization-in-progress display for trip history clearance



In the far-left digit, the lighting segments move round for

Note 1: The initialization operation does not initialize the analog input settings (C081, C082, C083, C121, C122, and C123) and thermistor coefficient setting (C085).

Note 2: The initialization operation does not initialize the settings of easy sequence user parameters (P100 to P131).

3. Debug Mode

Specifying "01" (ON) for the debugging-mode selection function (C091) displays the functions described below. Note: The debugging-mode selection function (C091) is not displayed when the factory settings are applied. To enable the display of said function, specify "00" (ALL) for the display selection function (b037).

3.1 Monitor Modes

No.	Function name	Function code	Range of monitoring
1	Monitoring of control frequency	d101	0.00-99.99/100.0-400.0(Hz)
2	Monitoring of trip factor determined by gate array	d105	00-FF
3	Monitoring of MCU No	d106	0000-9999
4	Monitoring of maximum voltage	d109	0.0-999.9(V)
5	Monitoring of temperature on printed circuit board	d110	-20.0-200.0(°C)
6	Monitoring of maximum temperature on printed circuit board	d111	-20.0-200.0(°C)

Each monitoring function is described below.

(1)Monitoring of control frequency (d101)

This monitoring function displays on the monitor the final control frequency output by the inverter.

(2) Monitoring of trip factor determined by gate array (d105)

Upon detecting a trip factor, the gate array transfers an 8-bit signal indicating the trip factor to the MCU as follows:

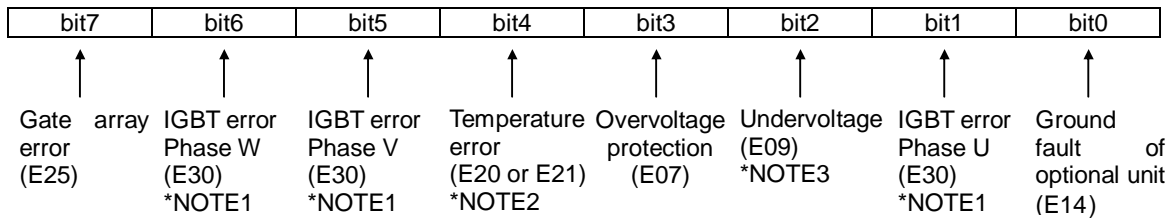

Note 1: The phase of an IGBT error cannot be determined on inverter models in which a single power module is mounted. In such cases, bit 6 indicates all IGBT errors.

Note 2: Error code "E20" is displayed upon the detection of lower cooling-fan speed.

This monitoring function (d105) displays a hexadecimal code on the monitor.

Example 1: Display of "10"

10 (hexadecimal) = 00010000 (binary)

Since bit 4 of the binary code is "1", this code indicates that a temperature error caused the trip.

Example 2: Display of "62"

62 (hexadecimal) = 01100010 (binary)

Since bits 6, 5, and 1 of the binary code are "1", this code indicates that IGBT errors in phases U, V, and W caused the trip.

Note 3: This monitoring function can be used to check the trip content only while the inverter is in a tripping state. See Section 3.3 for how to check the trip content according to the trip history.

Note 4: Normally, the inverter is automatically self-reset periodically from the trip due to undervoltage detected by the gate array. Therefore, bit 2 of the trip factor signal may not be set to "1" even if undervoltage occurs. Also note that undervoltage may be detected as a gate array error (E25) in case of undervoltage signal chatter.

(3)Monitoring of MCU No. (d106)

This monitoring function displays the software management number of preinstalled MCU software.

(4) Monitoring of maximum voltage (d109)

This monitoring function displays the maximum voltage detected across terminals P and N while the inverter is stopped.

(5) Monitoring of temperature on printed circuit board (d110)

This monitoring function displays the temperature on the printed board of main circuit in the power module.

(6) Monitoring of maximum temperature on printed circuit board (d111)

This monitoring function displays the maximum temperature on the printed board of main circuit board in the power module.

3.2 Function Modes

No.	Function name	Function code	Range of data
5	Function for factory adjustment	C170-C194	Change inhibited
6	Region code for inverter	C195	JP (intended for Japan)
7	Capacity code for inverter	C196	0.2 to 55.0 (kW)
8	Voltage class code for inverter	C197	200 (200 V class) or 400 (400 V class)
9	Inverter mode	C198	00(SJ700)

3.3 How To Reference the Data Area (d105) Corresponding to Trip History

In the data area you can directly reference the factors (determined by the gate array) of the past six trips. Do not change the value set as "C172".

- (1) Specify "FFFF" for "C170".
- (2) Specify "A56A" for "C171".
- (3) Reference the data of "C172". Record the last two digits of the data. (The range of data is "***00" to "***05".)
- (4) Specify one of the values listed in the table below for "C171" according to the target trip history data and the value of "C172".

Target history data	Value of "C172"					
	**00	**01	**02	**03	**04	**05
d081	A56E	A582	A596	A5AA	A5BE	A5D2
d082	A5D2	A56E	A582	A596	A5AA	A5BE
d083	A5BE	A5D2	A56E	A582	A596	A5AA
d084	A5AA	A5BE	A5D2	A56E	A582	A596
d085	A596	A5AA	A5BE	A5D2	A56E	A582
d086	A582	A596	A5AA	A5BE	A5D2	A56E

Example 1: Referencing the history data of "d083" when "C172" is "***02"

- (1) As shown in the above table, the data of "d083" is "A56E" when "C172" is "***02".
- (2) Specify "A56E" for "C171".

- (5) Reference the value displayed as "C172". The first two digits of the 4-digit value displayed correspond to the value of "d105".

↑
Code of the trip factor determined by gate array

Example 2:

When the value of "C172" is "08**", the trip factor is overvoltage protection because bit 3 is "1".

3.4 Inverter Setting

The logic board is common to all inverter models. If you change the inverter capacity or voltage class, you must also adjust the relevant settings of the logic board to those of the inverter.

3.4.1 Setting procedure

(1) Prepare for power-on.

(1.1) Connect the digital operator to the inverter.

(2) Turn the inverter power on.

(2.1) Select "00" (ALL) for the display selection (b037).

(3) Set the region, output capacity, voltage class, and default data codes.

(3.1) Switch the inverter to debug mode.

(Setting method)

Display code "C091" on the monitor, press the FUNC key, enter "01", and then press the STR key.

(3.2) Set the region code.

(Setting method)

Display code "C195" on the monitor, press the FUNC key, select one of the codes listed in the table below, and then press the STR key.

Region where to use the inverter	Region code (C195)
Japan	JP
Europe	EU
U.S.A.	USA

Note: Do not set any code other than "JP".

(3.3) Set the capacity code.

(Setting method)

Display code "C196" on the monitor, press the FUNC key, select one of the codes listed in the table below, and then press the STR key.

Inverter model	Capacity code (C196)
150LF**/150HF**	15.0
185LF**/185HF**	18.5
220LF**/220HF**	22.0
300LF**/300HF**	30.0
370LF**/370HF**	37.0

(3.4) Set the voltage class code.

(Setting method)

Display code "C196" on the monitor, press the FUNC key, select one of the codes listed in the table below, and then press the STR key.

Voltage class	Voltage class (C197)
200 V class	200
400 V class	400

(3.5) Select default data.

(Setting method)

Display code "b085" on the monitor, press the FUNC key, select one of the codes listed in the table below, and then press the STR key.

Region where to use the inverter	Default data code (b085)
for Japan	00
for Europe	01
for the U.S.A.	02

(4) Perform data initialization. (See Section 2.5.)

(5) After initialization ends (with code "d001" displayed on the monitor), turn the inverter power off.

(6) Turn the inverter power on.

3.4.2 Confirming the completion of initialization

(1) Confirm the voltage class setting.

(Confirming method)

Display code "A082" on the monitor, press the FUNC key, and then confirm that data shown in the table below is displayed on the monitor.

Note: Initialization switches the display mode of the digital operator to basic mode. Therefore, display code "b037" on the monitor before confirmation, and then select "00".

Inverter model	Value of "b082"
-LFF/-LFUF	200
-HFF/-HFUF/-HFEF	400

(2) Confirm the capacity setting.

(Confirming method)

Display code "H003" on the monitor, press the FUNC key, and then confirm that the set capacity code data is displayed on the monitor. After confirmation, change the value of "b037" back to "04".

4.The check of control power supply voltage and a control signal

4.1 Control power supply

Item	Tolerance level	Measurement place	
		+	-
PV5 +5V power supply	4.5-5.5V	J1 connector 5pin,6pin	Control terminal L
PV12 +12V power supply	10.8V-13.2V	J1 connector 3pin	Control terminal L
Nv12 -12V power supply	-13.2V--10.8V	J1 connector 4pin	Control terminal L
PV24 +24V power supply	21.6V-26.4V	J1 connector 2pin,3pin Control terminal P24	Control terminal CM1

4.2 Control signal

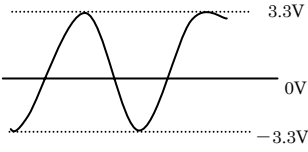
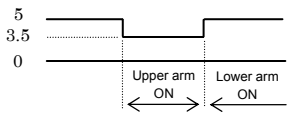
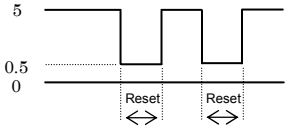
Signal	Measurement place	The controls of operation	Observation waveform
VDC	J1 connector 32pin-L	A main circuit direct-current voltage detected signal VDC=6.396V/400V*VPN(200Vclass) VDC=6.396V/800V*VPN(400Vclass)	Direct-current voltage
IUF IWF	J1 connector 31pin-L J1 connector 30pin-L	A motor current detected signal At the time of inverter rated load:About 3.3V peak.	
TRIP	J1 connector 17pin-L	The signal at the time of carrying out a trip by the trip factor which a gate array judges (P3-1 reference)	Direct-current voltage
PHF	J1 connector 37pin-L	Phase failure protection detected signal Normal:5V(H) Phase failure detection :about 0.5V(L)	Direct-current voltage
IPL	J1 connector 33pin-L	The instantaneous power failure signal of R0-T0 part. Power On :about 0.5V(L) Power Off : 5V(H)	Direct-current voltage
GS	J1 connector 36pin-L	Power-module protection Under operation :about 5V(H) Under a stop :about 0.5V(L)	Direct-current voltage
US VS WS	J1 connector 15pin-L J1 connector 35pin-L J1 connector 36pin-L	PWM signal Upper arm ON :about 3.5V(L) Lower arm ON :about 5V(H)	
TRES	J1 connector 40pin-L	The trip distinguished by GA is canceled. Normal :about 5V(H) Under reset :about 0.5V(L)	

5. Maintenance and Inspection

5.1 Precautions for Maintenance and Inspection

5.1.1 Daily inspection

Basically check your system during the inverter operation to confirm that:

- 1) the motor is operating according to the settings on the inverter,
- 2) the installation environment is normal,
- 3) the cooling system is normal,
- 4) no abnormal vibrations and noise are generated,
- 5) no equipment overheating and discoloration are found, and
- 6) there are no unusual smells.

While the inverter is operating, measure the inverter input power voltage with a multimeter to confirm that:

- 1) the power supply voltage does not fluctuate often, and
- 2) the voltages between the power supply wires are balanced.

5.1.2 Cleaning

Always keep the inverter clean. When cleaning the inverter, wipe off dirt and stains on the inverter surface lightly with a soft cloth dipped in a neutral detergent solution.

Note:

Do not use solvents such as acetone, benzene, toluene, and alcohol for cleaning. These solvents cause the inverter surface to dissolve or the coating on the surface to peel off. In particular, never use a detergent or alcohol to clean the monitor of the digital operator.

5.1.3 Periodic inspection

Check those inverter sections and parts which are accessible only while the inverter is stopped and which should be inspected regularly. When you intend to carry out a periodic inspection, contact your local Hitachi Distributor.

During a periodic inspection, perform the following:

- 1) Check that the cooling system is normal. Clean the air filter as needed.
- 2) Check the screws and bolts for tightness, and retighten them. Screws and bolts may have loosened because of vibrations and temperature changes. Check them carefully.
- 3) Check to ensure conductors and insulators are not corroded or damaged.
- 4) Measure the dielectric breakdown voltage of insulators.
- 5) Check the cooling fan, smoothing capacitors, and relays, and replace them if necessary.

5.2 Daily and Periodic Inspections

Part to inspect	Inspection item	Detail of inspection	Inspection cycle			Inspection method	Criterion	Test equipment
			Daily	Periodic				
				Annual	Biennial			
General	Environment	Check the ambient temperature, humidity, and dust.	○			See Section 2.1, "Installation."	The ambient temperature must be within -10°C to +50°C without condensation. The ambient humidity must be 90% RH or less without condensation.	Thermometer, hygrometer, recorder
	Whole inverter	Check for abnormal vibrations and noise.	○			Check visually and by listening.	There must be no abnormality found.	
	Power supply voltage	Check that the main circuit voltage is normal.	○			Measure the voltage between the main circuit terminals R, S, and T.	The measured voltage must be within the allowable tolerance for AC power voltage.	Tester, digital multimeter
Main circuit	General check	(1) Check the ground resistance between the main circuit and ground terminals with a megger.		○		Disconnect all input and output cables from the inverter's main circuit terminal block, detach the control circuit terminal block from the inverter, and remove the jumper for switching the inverter's internal filter function. Subsequently, measure the insulation resistance between the ground terminal and the jumper connecting all the following terminals: R, S, T, U, V, W, P, PD, N, RB, R0, and T0	The measured ground resistance must be 5MΩ or more.	500 VDC class megger
		(2) Check screws and bolts for loosening.	○			Retighten loose screws and bolts.	There must be no abnormality found.	
		(3) Check each part for any trace of overheating.	○			Check visually.	There must be no abnormality found.	
	Connecting conductors and cables	(1) Check the conductors for distortion.	○			Check visually	There must be no abnormality found.	
		(2) Check the cable insulations for damage.	○					
	Terminal block	Check the terminal blocks for damage.	○			Check visually	There must be no abnormality found.	
	Inverter circuit and converter circuit (including resistors)	Check the resistance between terminals.		○		Remove all cables from the inverter's main circuit terminal block. Use a tester (in 1Ω range mode) to measure the following: - Resistance between terminals R, S, and T and terminals P and N - Resistance between terminals U, V, and W and terminals P and N	See Section 6.5, "Method of Checking the Inverter and Converter Circuits." Standard operating life of inverter circuit until replacement: 106 cycles of starting and stopping (*3)	Analog tester
	Smoothing capacitor	(1) Check for liquid leak.	○			Check visually.	There must be no abnormality found.	Capacitance meter
		(2) Check that the relief valve does not protrude or swell.	○				Target operating life until replacement: 10 years (*1) (*3)	
	Relay	(1) Check that no fluttering sound is generated during the relay operation.		○		Check by listening.	There must be no abnormality found.	
(2) Check the contacts for damage.			○		Check visually.	There must be no abnormality found.		
Control and protective circuits	Operation	(1) While performing a unit operation of the inverter, check the balance output voltage among the individual phases.		○		Measure the voltage between the cables connected to the main circuit terminals U, V, and W.	The inter-phase voltage balance must be as follows: 200 V class models: 4 V or less 400 V class models: 8 V or less	Digital multimeter, rectifier instrument, and voltmeter
		(2) Carry out a sequential protection operation test, and check the protective and display circuits for any abnormality.		○		Short-circuit or open the protective circuit outputs as a simulation.	An error must be detected according to the sequence.	
Cooling system	Cooling fan	(1) Check for abnormal vibrations and noise	○			Turn the fan manually during the inverter power-off status.	The fan must rotate smoothly. There must be no abnormality found.	
		(2) Check the joints for loosening.		○		Check visually.	Standard operating life until replacement: 10 years (*2) (*3)	
	Heat sink	Check for clogging.		○		Check visually.	The heat sink must not be clogged.	
Display	Monitor	(1) Check that all LEDs light up normally.	○			Check visually.	The LEDs must light up normally.	
		(2) Clean the monitor.		○		Clean the monitor with a rag.		
	Meter	Check that meter readings are normal.	○			Check the meter readings on the panel.	The readings must meet the standard and control values.	Voltmeter and ammeter
Motor	General	(1) Check for abnormal vibrations and noise.	○			Check vibrations and noise visually, by listening, and with physical senses.	There must be no abnormality found.	
		(2) Check for unusual smells.	○			Check for any unusual smells caused by overheating or damage.	There must be no abnormality found.	
	Insulation resistance	Check the ground resistance between all motor terminals and the ground terminal with a megger.		○		Remove the cables from the inverter's main circuit terminals U, V, and W, connect the motor wires (for three phases) with one another, and measure the ground resistance between the motor wires and the ground terminal.	The measured ground resistance must be 5MΩ or more.	500 VDC class megger

*1 The operating life of the smoothing capacitor is under the influence of the ambient temperature. Refer to Section 6.6, "Smoothing-Capacitor Life Curve," as a standard for the operating life until replacement.

*2 The operating life of the cooling fan varies depending on environmental conditions, including the ambient temperature and dust. Check the status of the cooling-fan operation during daily inspections.

*3 The standard operating life (number of years or operation cycles) and the data described in Section 6.6, "Smoothing-Capacitor Life Curve," are based on the expected design life, but they do not indicate the guaranteed life of any parts.

5.3 Ground Resistance Test with a Megger

When testing an external circuit with a megger, disconnect all the external circuit cables from the inverter to prevent it from being exposed to the test voltage.

Use a tester (in high-resistance range mode) for a conduction test on the control circuit. Do not use a megger or buzzer for that purpose.

Apply the ground resistance test using a megger only to the main circuit of the inverter. Do not carry out the test using a megger for its control circuit.

Use a 500 VDC megger for the ground resistance test.

Before the main circuit test with a megger, remove the jumper for switching the inverter's internal filter function, and then connect terminals R, S, T, U, V, W, P, PD, N, RB, R0, and T0 by wires as shown in the figure below. Subsequently, carry out the test.

After the test using the megger, remove the wires from terminals R, S, T, U, V, W, P, PD, N, RB, R0, and T0, and connect the jumper for switching the inverter's internal filter function at the original position.

Note that only inverter models with a capacity of less than 22 kW have the RB terminal.

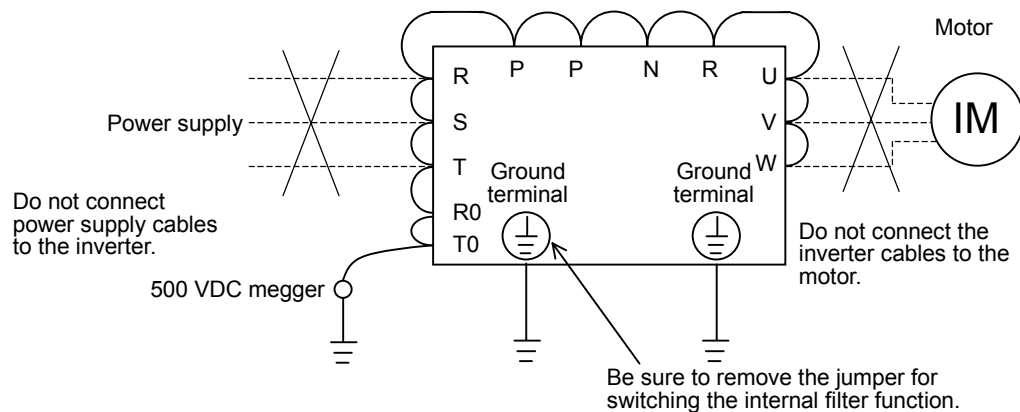

5.4 Withstand Voltage Test

Do not carry out a withstand voltage test for the inverter. The test may damage its internal parts or cause them to deteriorate.

5.5 Method of Checking the Inverter and Converter Circuits

You can check the quality of the inverter and converter circuits by using a tester.

(Preparation)

- 1) Remove the external power supply cables from terminals R, T, and T, the motor cables from terminals U, V, and W, and the regenerative braking resistor cables from terminals P and RB.
- 2) Prepare a tester. (Use the 1Ω-measuring range.)

(Checking method)

Measure the current conduction at each of the inverter's main circuit terminals R, S, T, U, V, W, RB, P, and N while switching the tester polarity alternately.

Note 1: Before checking the circuits, measure the voltage across terminals P and N with the tester in DC voltage range mode to confirm that the smoothing capacitor has fully discharged electricity.

Note 2: When the measured terminal is nonconductive, the tester reads a nearly infinite resistance. The tester may not read the infinite resistance if the measured terminal flows a current momentarily under the influence of the smoothing capacitor.

When the measured terminal is conductive, the tester reading is several ohms to several tens of ohms. The measured values may vary slightly, depending on the types of circuit devices and tester. However, if the values measured at the terminals are almost the same, the inverter and converter circuits have adequate quality.

Note 3: Only inverter models with capacity of 22 kW or less have the BRD circuit.

		Tester polarity		Measurement result
		⊕ (red)	⊖ (black)	
Converter circuit	D1	R	PD	Nonconductive
		PD	R	Conductive
	D2	S	PD	Nonconductive
		PD	S	Conductive
	D3	T	PD	Nonconductive
		PD	T	Conductive
D4	R	N	Conductive	
	N	R	Nonconductive	
D5	S	N	Conductive	
	N	S	Nonconductive	
D6	T	N	Conductive	
	N	T	Nonconductive	
Inverter circuit	TR1	U	P	Nonconductive
		P	U	Conductive
	TR2	V	P	Nonconductive
		P	V	Conductive
	TR3	W	P	Nonconductive
		P	W	Conductive
TR4	U	N	Conductive	
	N	U	Nonconductive	
TR5	V	N	Conductive	
	N	V	Nonconductive	
TR6	W	N	Conductive	
	N	W	Nonconductive	
BRD circuit	TR7	RB	P	Nonconductive
		P	RB	Conductive
		RB	N	Nonconductive
		N	RV	Nonconductive

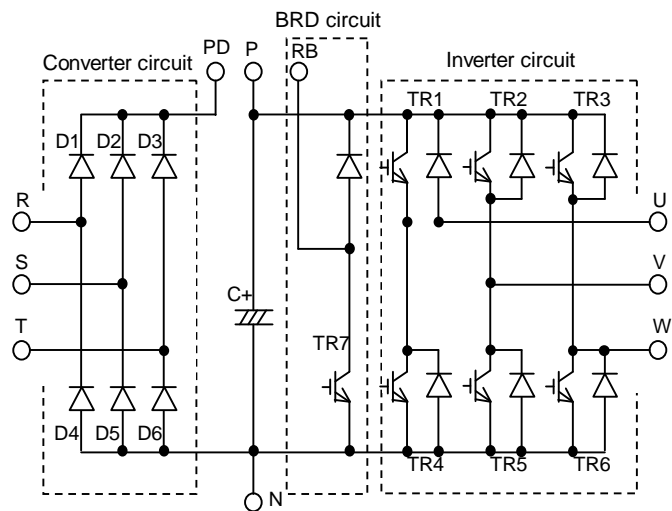

5.6 Replacing Parts

The inverter consists of many parts and it functions normally only when all the parts operate normally. The table below lists the parts that may be subject to changes in characteristics and malfunctions after long-time use, even normally, over a specified number of years.

Each part should be replaced at specified intervals to prevent inverter faults and changes in inverter characteristics. Be sure to periodically replace the parts for preventive maintenance.

Part name	Standard replacement interval	Replacement and maintenance methods
Cooling fan	10 years	Replace with a new part.
DC bus capacitors of main circuit	10 years	Replace with a new part. (Decide whether to replace after examination.)
Electrolytic capacitors on the board	10 years	Replace with a new part. (Decide whether to replace after examination.)
Relay	-	Inspect the part after examination.

(1) Cooling fans

The inverter has cooling fans to cool the internal heat-generating parts. The service life of each cooling-fan bearing is assumed to be about 100,000 hours, though it may vary depending on the inverter operating environment.

On an inverter being run continuously, the cooling-fan unit must usually be replaced at 10-year intervals. Even during the expected 10-year lifespan, the cooling-fan unit must be immediately replaced in case any abnormal vibrations or sounds are detected when inspecting the inverter.

1) Removing the molded-case type of cooling-fan unit

- <1> Remove the terminal block cover and front cover.
- <2> Confirm that the Charge lamp goes off.
- <3> While pushing in the claws of the cooling-fan mounting plate, lift the plate to remove it from the inverter.
- <4> Remove the fan connector.
- <5> Remove the cooling fans from the cooling-fan mounting plate.

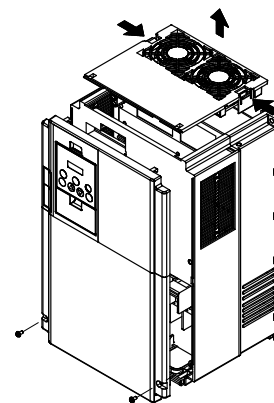

2) Mounting the molded-case type of cooling-fan unit

- <1> Attach the cooling fans to the cooling-fan mounting plate so that the fans are correctly oriented.
- <2> Connect the fan connector to terminal J21 or J22 (depending on the inverter model) of the main circuit board.
- <3> Mount the cooling-fan mounting plate on the inverter.
- <4> Mount the front cover and terminal block cover.

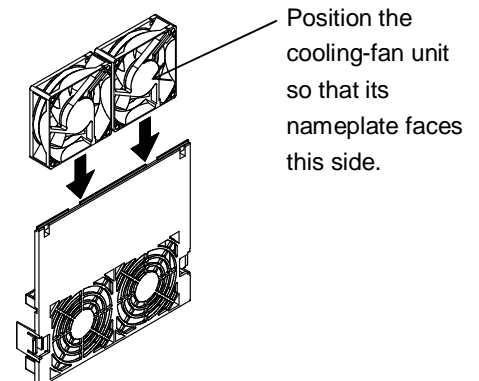

3) Removing the sheet-metal-case type of cooling-fan unit

- <1> Remove the terminal block cover and front cover.
- <2> Make sure that the Charge lamp goes off.
- <3> Remove the screws at the top.
- <4> Lift the cooling-fan mounting plate to remove it from the inverter.
- <5> Remove the fan connector.
- <6> Remove the cooling fans from the cooling-fan mounting plate.

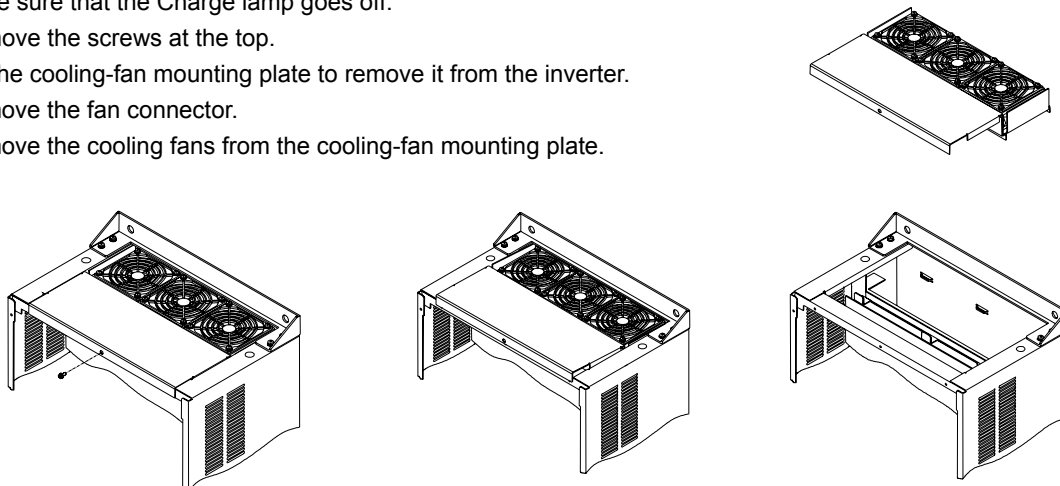

4) Mounting the sheet-metal-case type of cooling-fan unit

- <1> Attach the cooling fans to the cooling-fan mounting plate so that the fans are oriented correctly.
- <2> Connect the fan connector to terminal J21, J22, or J23 (depending on the inverter model) of the main circuit board.
- <3> Mount the cooling-fan mounting plate on the inverter and secure it with screws.
- <4> Mount the front cover and terminal block cover.

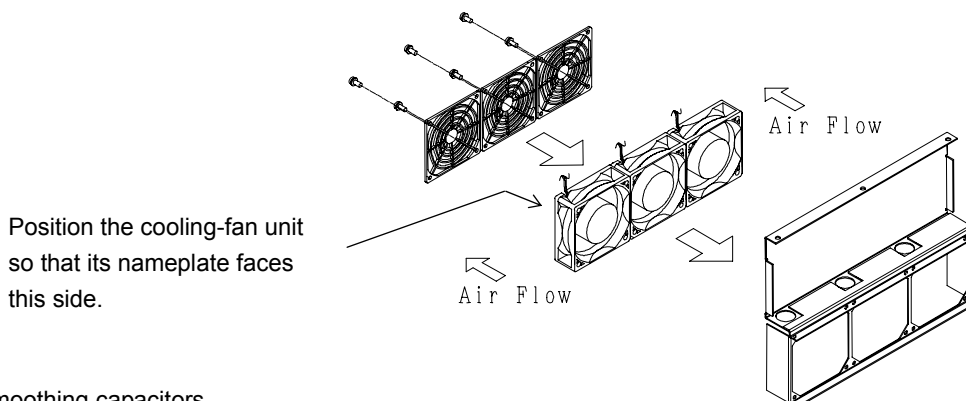

(2) Smoothing capacitors

The DC section of the inverter main circuit uses high-capacity aluminum electrolytic capacitors as smoothing filter components. Since chemical reactions occur inside the capacitors, the service life of these parts largely depends on the ambient temperature and operating conditions. Capacitors used in a standard operating environment must be replaced after about 10 years. However, each capacitor must be immediately replaced if found abnormal upon a visual inspection or if periodic inspection finds capacity to be 80% or less of the rating.

1) Removing the molded-case type of smoothing capacitors

(note) This feature to remove the smoothing capacitor easily is not available for the mold case type (up to 11Kw)

- <1> Remove the terminal block cover.
- <2> Make sure that the Charge lamp goes off.
- <3> Remove the backing plate.
- <4> Remove the screws connecting the capacitor unit to the main circuit terminal block.
- <5> Remove the screws fixing the capacitor mounting plate to the inverter casing.
- <6> Pull down the capacitor mounting plate.
- <7> Remove the capacitor unit from the capacitor mounting plate.

2) Mounting the molded-case type of smoothing capacitors

(note) This feature to remove the smoothing capacitor easily is not available for the mold case type (up to 11Kw)

- <1> Place the capacitor unit on the capacitor mounting plate.
- <2> Fit both edges of the capacitor mounting plate into the guide grooves in the inverter casing, and then insert the plate into the inverter.
- <3> Secure the capacitor board to the main circuit terminal block by using the connection terminal screws.
- <4> Fix the capacitor mounting plate to the inverter casing by using the screws.
- <5> Mount the backing plate.
- <6> Mount the terminal block cover.

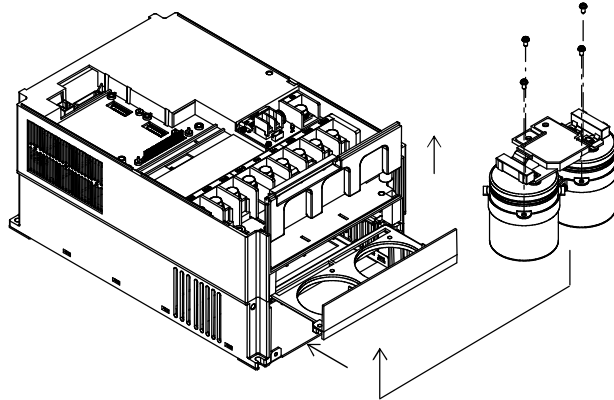

3) Removing the sheet-metal-case type of smoothing capacitors

- <1> Remove the terminal block cover.
- <2> Make sure that the Charge lamp goes off.
- <3> Remove the lower screws from terminal block terminals P and N.
- <4> Remove the screws fixing the capacitor mounting plate.
- <5> Pull down the capacitor mounting plate.
- <6> Remove the busbar and resistors, and then remove the capacitor unit from the capacitor mounting plate.

4) Mounting the sheet-metal-case type of smoothing capacitors

- <1> Set the capacitor unit on the capacitor mounting plate and secure the unit in place by using the screws.
- <2> Mount the busbar and resistors in the original positions, and then secure these parts in place by using the screws.
- <3> Fit the capacitor mounting plate into the inverter casing.
- <4> Fix the capacitor mounting plate to the inverter casing by using the screws.
- <5> Attach the lower screws to terminal block terminals P and N.
- <6> Mount the terminal block cover.

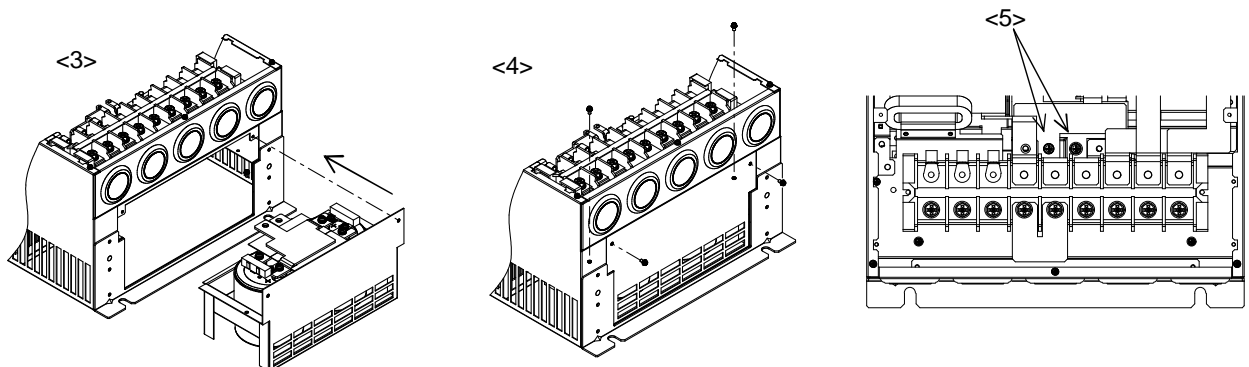

(3) Smoothing capacitors (on PCB)

Smoothing capacitors on PCB is recommended to be replaced after 10 years of usage under standard installation, which is the same as main Smoothing capacitors. If abnormality is found by visual inspection and/or if the control power supply is not activated after the power ON, the capacitors are required to be replaced.

(The replacement is done by the PCB replacement, since the capacitors themselves cannot be replaced.)

(How to replace)

The replacement is done by referring to the structure diagram attached. Please pay attention to the length of the screws. Make sure you're using the correct screws when re-assembling.

(Note)

Please pay attention to the tab portion when disassembling. There is a possibility of damaging the mold case type. (model up to 22kW.)

<1> Remove the terminal block cover, front cover and cooling fan mounting plate, which is the same procedure as cooling fan replacement.

<2> Remove the connection cable (flat cable), which is connected to the control board and main board.

<3> Remove the cable fixing plate and short circuit bar attached to the P-PD terminal of the main board.

<4> Remove two screws on the mold case, and remove the case as shown in figure below. Please pay attention not to damage the tabs.

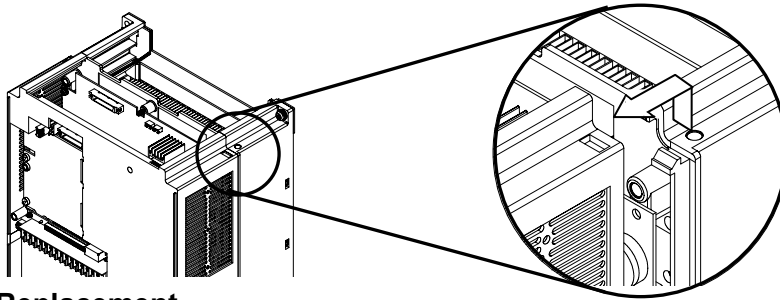

5.7 Inverter Replacement

When replacing your inverter with a new one, you can do so without disconnecting the wiring on the control circuit terminal block of the old inverter.

(Replacement procedure)

<1> Remove the terminal block cover.

<2> Make sure that the Charge lamp goes off.

<3> Remove the screws from both sides of the control circuit terminal block board.

<4> Pull out the control circuit terminal block board toward the front.

<5> When mounting the control circuit terminal block board on the new inverter, be careful not to bend the connector pins on the control circuit terminal block board.

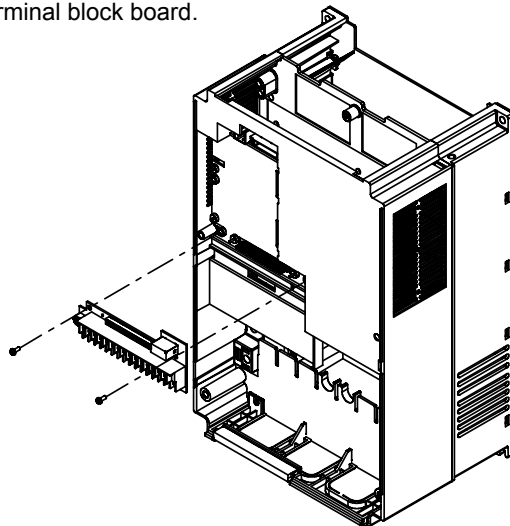

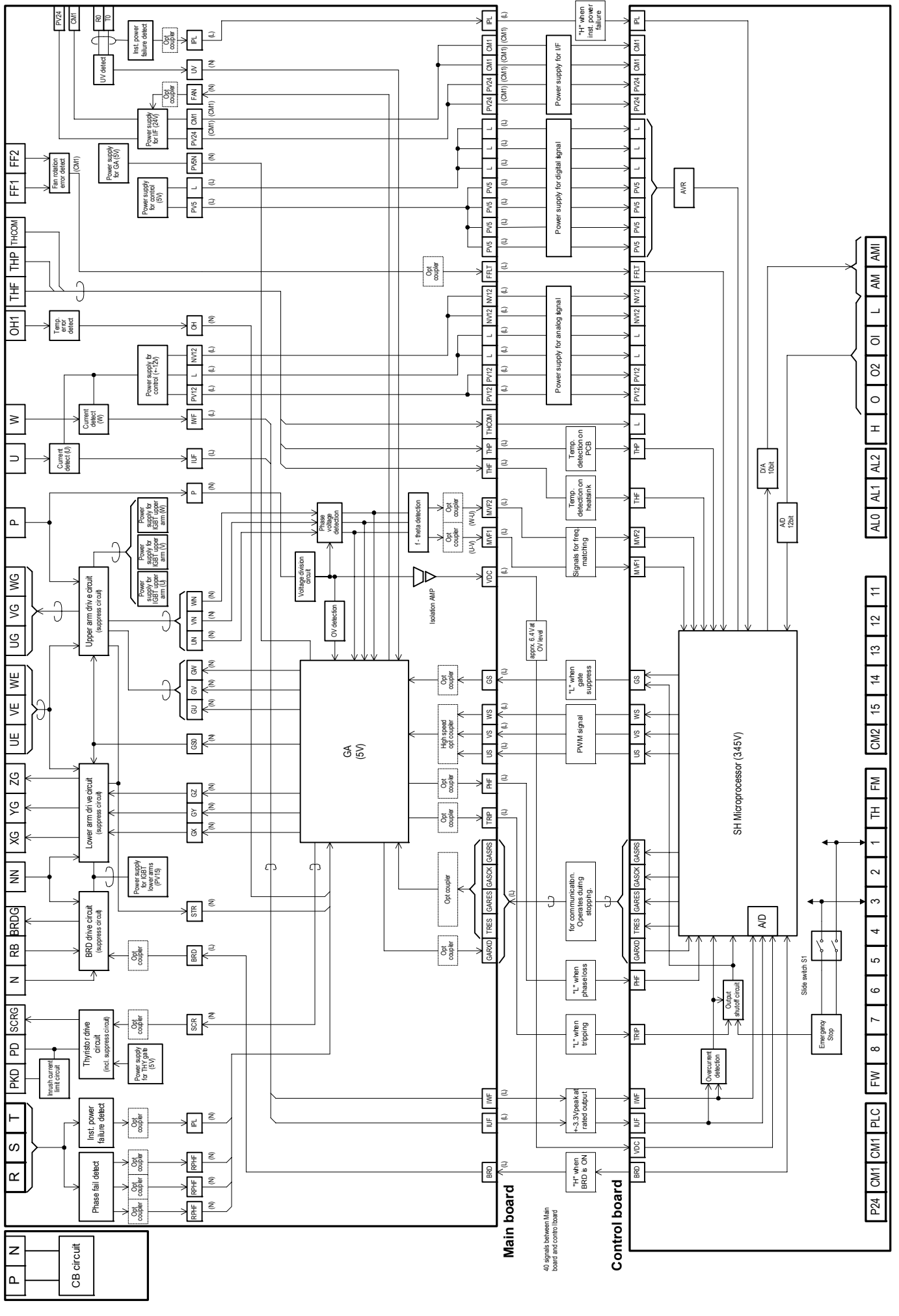

Main board

Control board

40 signals between Main board and control board

P24 CM1 CM1
AL0 AL1 AL2 H O O2 O1 L AM AMI

CM2 15 14 13 12 11

TH FM

1 2 3 4 5 6 7 8

FW

PLC

PLC

FW

TH

FM

CM2 15 14 13 12 11

AL0 AL1 AL2 H O O2 O1 L AM AMI

SH Microprocessor (3445V)

AD 12bit
D/A 10bit

Emergency Stop
Slide switch S1

Output shunt circuit

Overcurrent detection

for communication. Operates during supplying.

"L" when phase loss

"L" when tripping

"L" when gate suppress

PWM signal

Signals for freq. matching

Temp. detection on PCB

Temp. detection on heat sink

Power supply for digital signal

Power supply for analog signal

Power supply for I/F

"H" when inst. power failure

approx. 6.4V at OV level

Isolation AMP

f - phase detection

Voltage division board

OV detector

Power supply for upper arm (U)

Power supply for lower arm (L)

Power supply for control (-24V)

Inst. power failure detect

UV detect

UV detect

UV detect

UV detect

UV detect

UV detect

Temp. detect

Temp. detect

Temp. detect

Temp. detect

Temp. detect

Temp. detect

Temp. detect

Temp. detect

Temp. detect

Temp. detect

Temp. detect

Temp. detect

Temp. detect

Temp. detect

Temp. detect

Inst. power failure detect

UV detect

UV detect

UV detect

UV detect

UV detect

UV detect

UV detect

UV detect

UV detect

UV detect

UV detect

UV detect

UV detect

UV detect

Inst. power failure detect

UV detect

UV detect

UV detect

UV detect

UV detect

UV detect

UV detect

UV detect

UV detect

UV detect

UV detect

UV detect

UV detect

UV detect

Inst. power failure detect

UV detect

UV detect

UV detect

UV detect

UV detect

UV detect

UV detect

UV detect

UV detect

UV detect

UV detect

UV detect

UV detect

UV detect

Inst. power failure detect

UV detect

UV detect

UV detect

UV detect

UV detect

UV detect

UV detect

UV detect

UV detect

UV detect

UV detect

UV detect

UV detect

UV detect

Inst. power failure detect

UV detect

UV detect

UV detect

UV detect

UV detect

UV detect

UV detect

UV detect

UV detect

UV detect

UV detect

UV detect

UV detect

UV detect

Inst. power failure detect

UV detect

UV detect

UV detect

UV detect

UV detect

UV detect

UV detect

UV detect

UV detect

UV detect

UV detect

UV detect

UV detect

UV detect

Inst. power failure detect

UV detect

UV detect

UV detect

UV detect

UV detect

UV detect

UV detect

UV detect

UV detect

UV detect

UV detect

UV detect

UV detect

UV detect

Inst. power failure detect

UV detect

UV detect

UV detect

UV detect

UV detect

UV detect

UV detect

UV detect

UV detect

UV detect

UV detect

UV detect

UV detect

UV detect

SJ700-055-110LF2 Circuit Diagram**

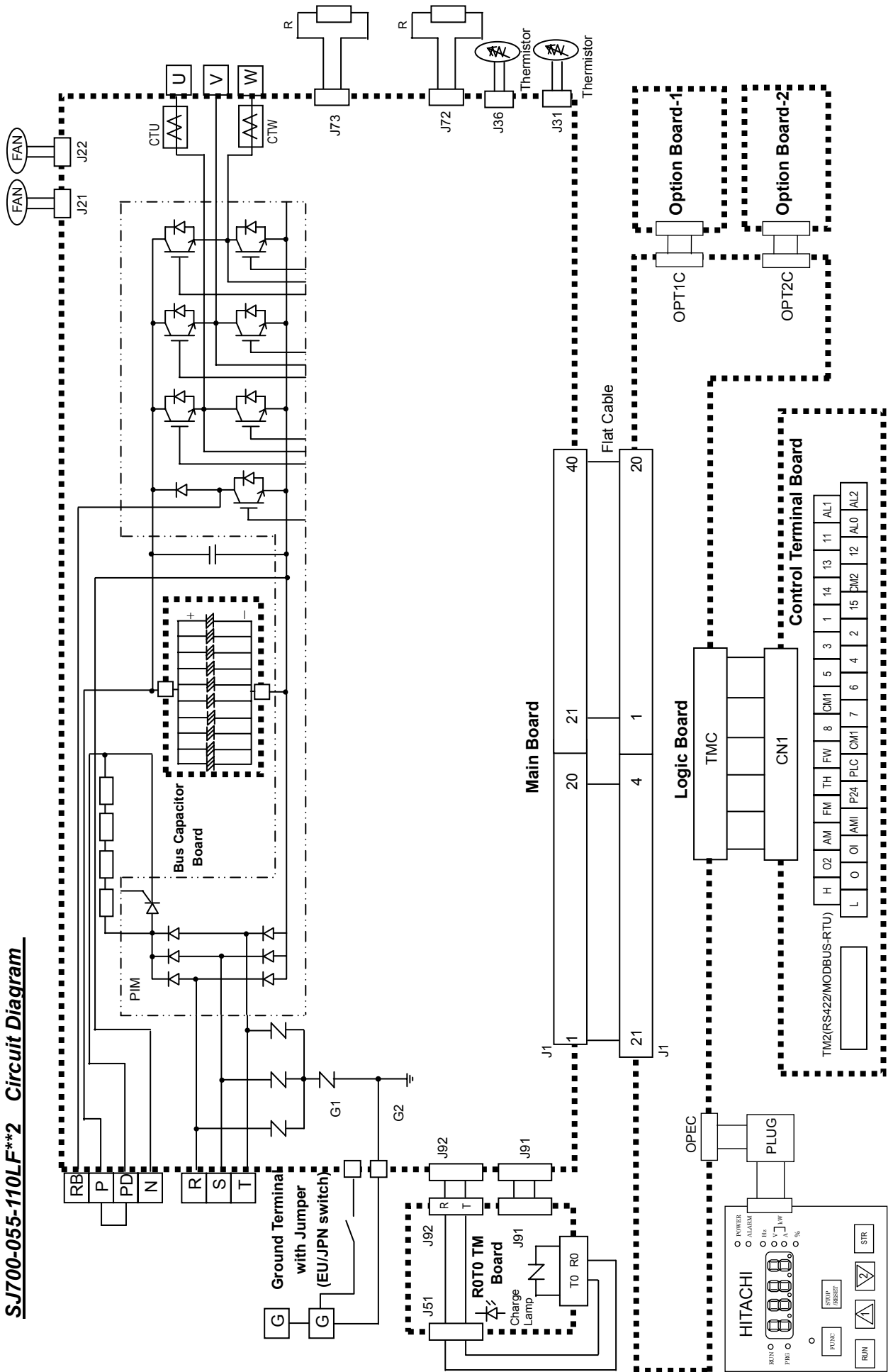

SJ700-150LF2 185LF**2 Circuit Diagram**

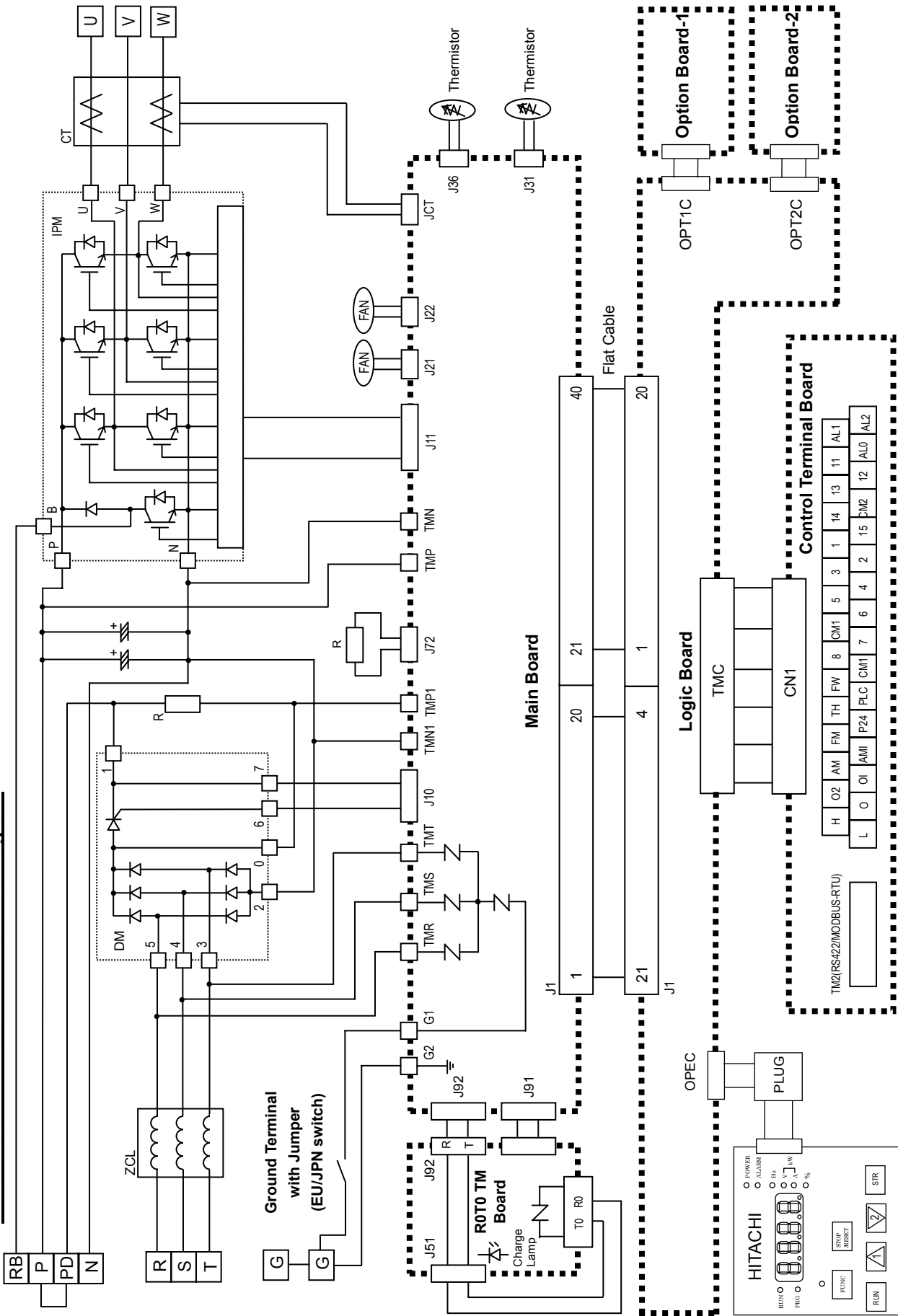

SJ700-220LF**2 Circuit Diagram

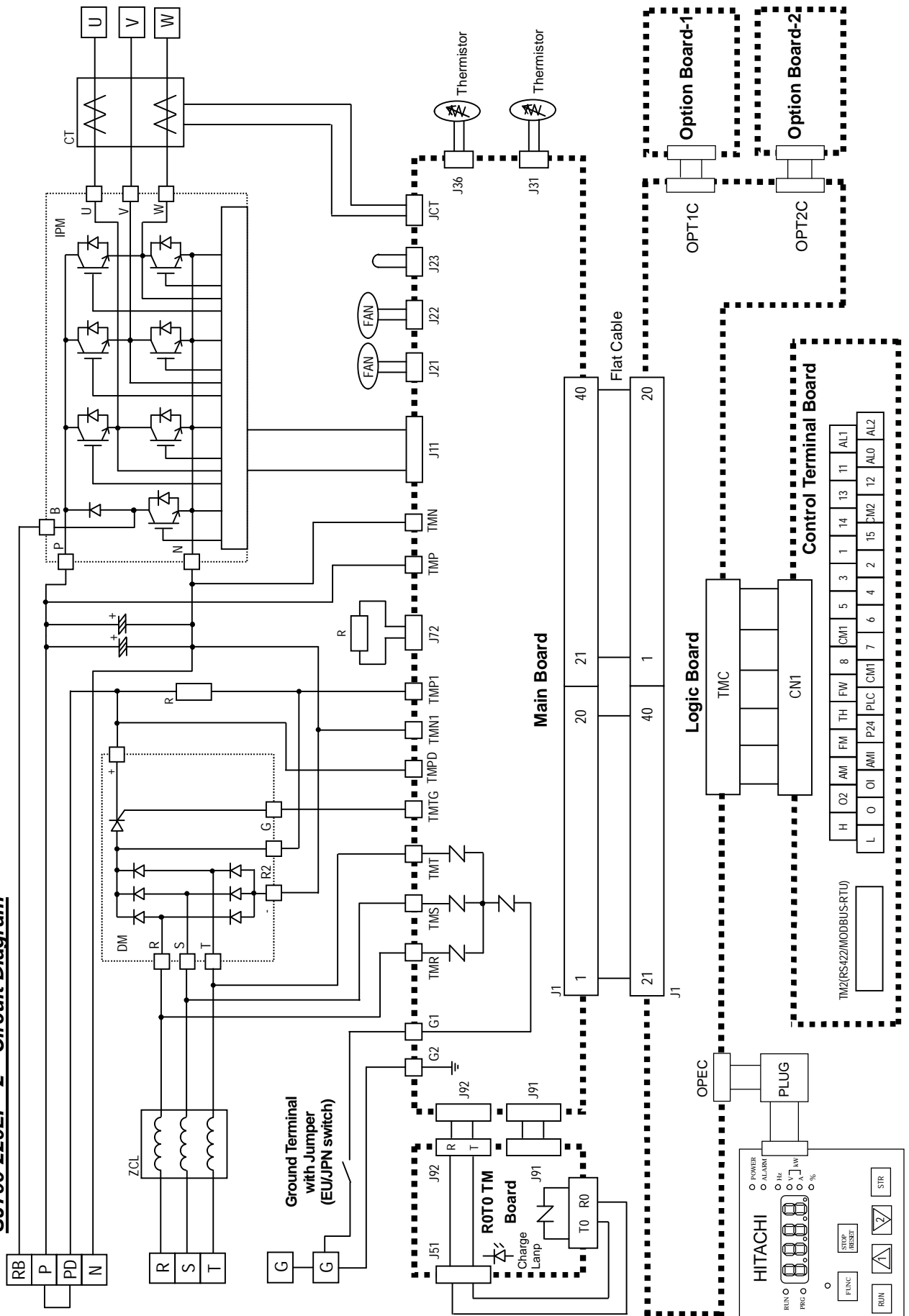

SJ700-300LF2 Circuit Diagram**

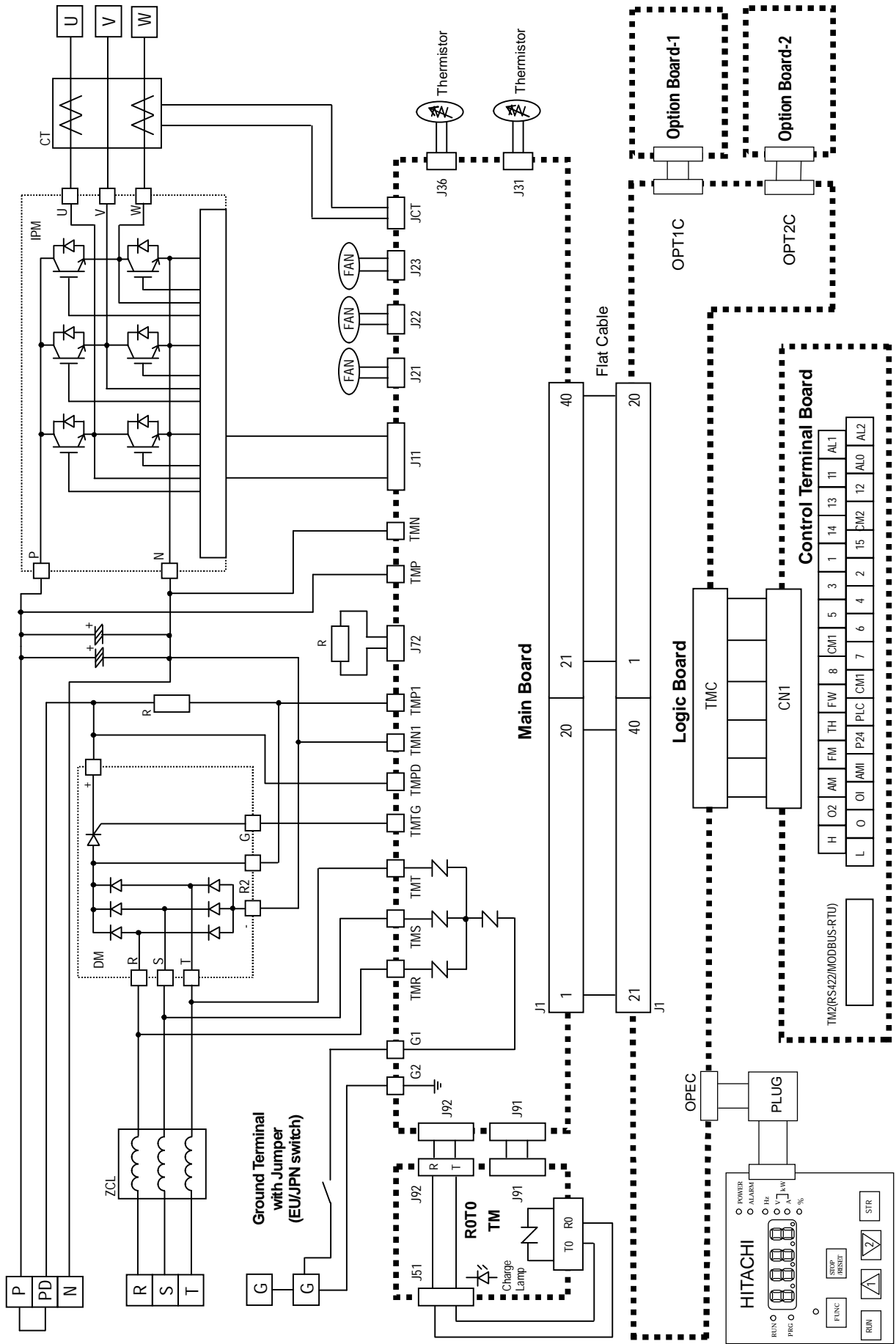

SJ700-370LF**2 Circuit Diagram

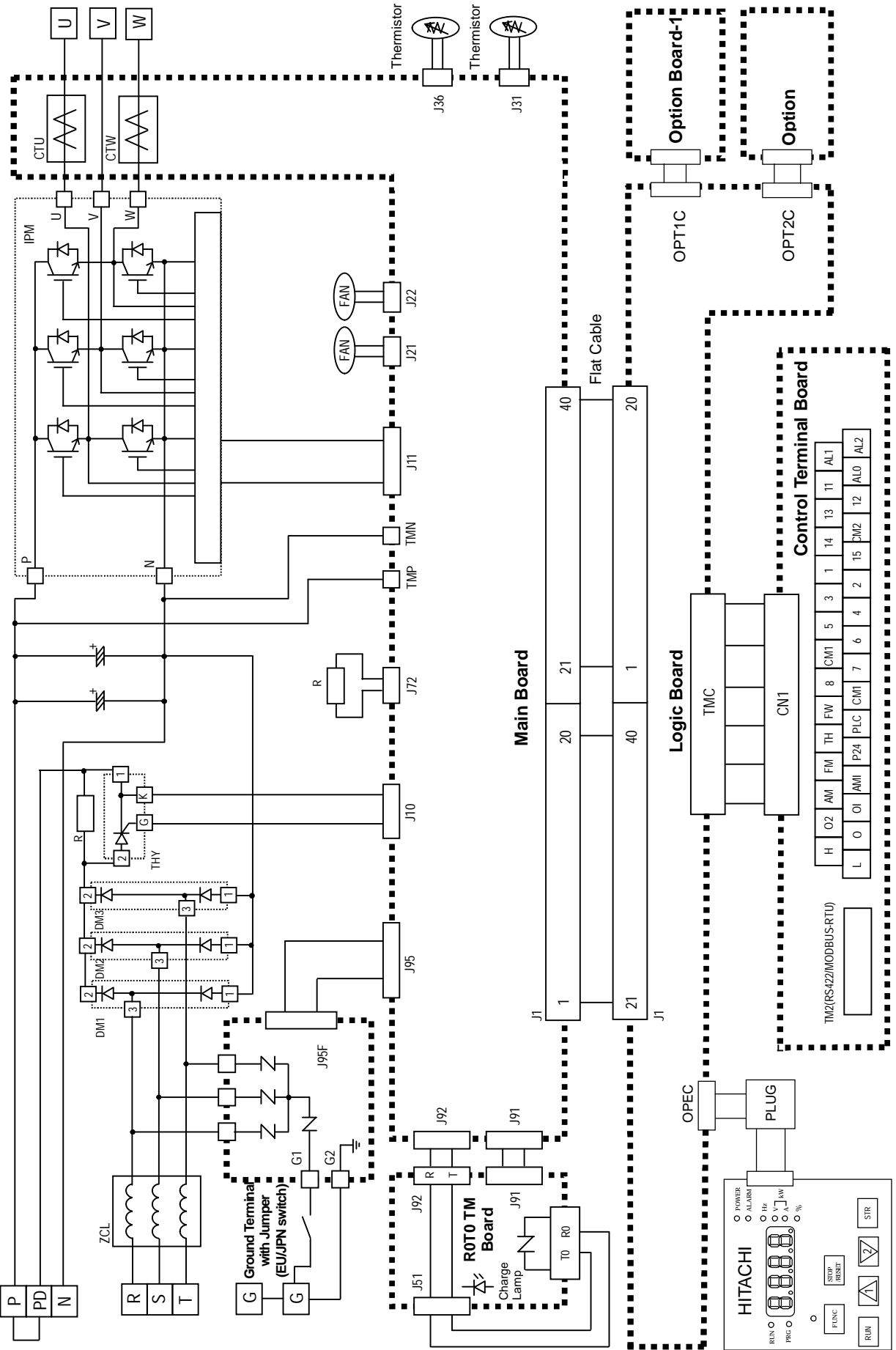

SJ700-450LF**2 Circuit Diagram

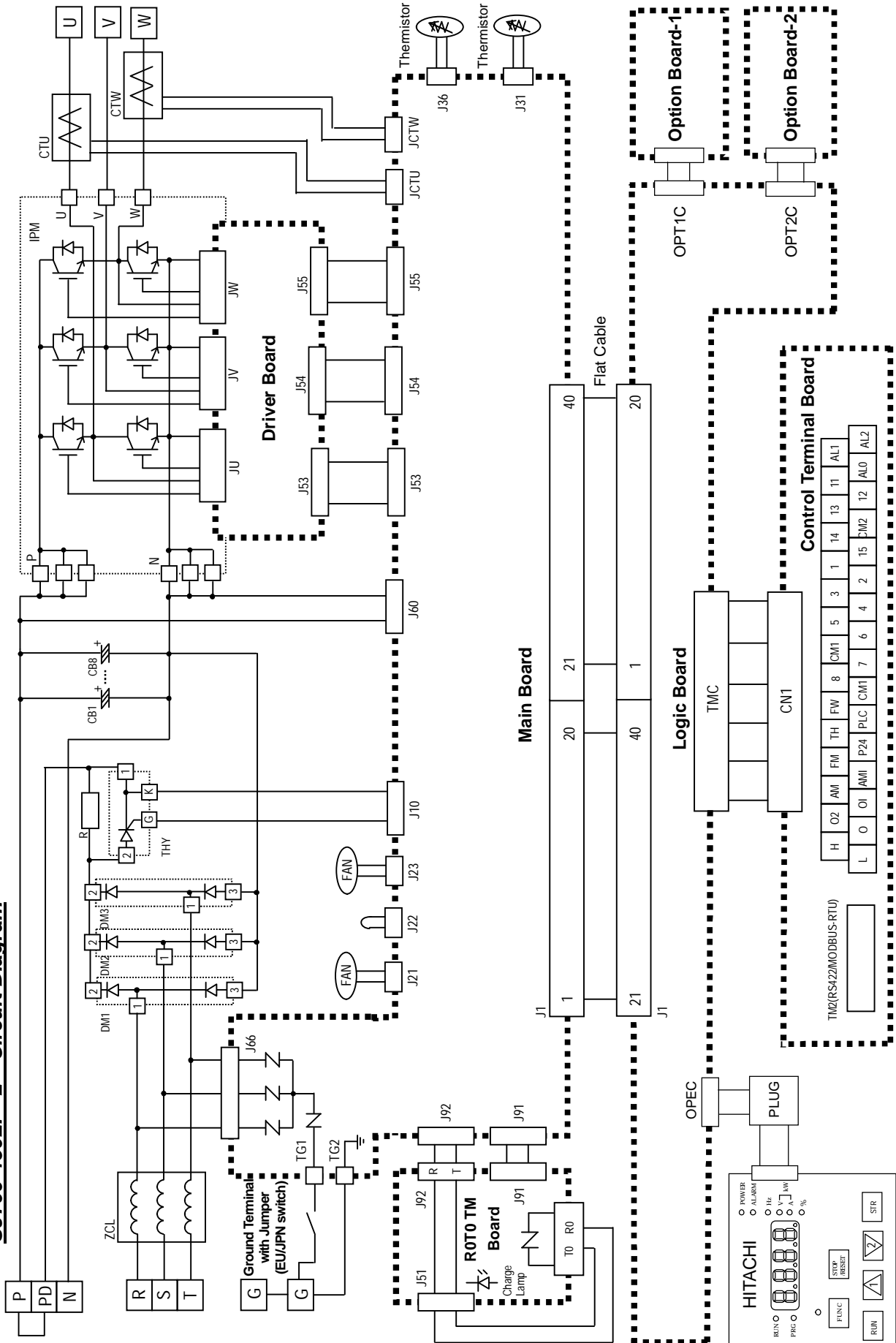

SJ700-550LF2 Circuit Diagram**

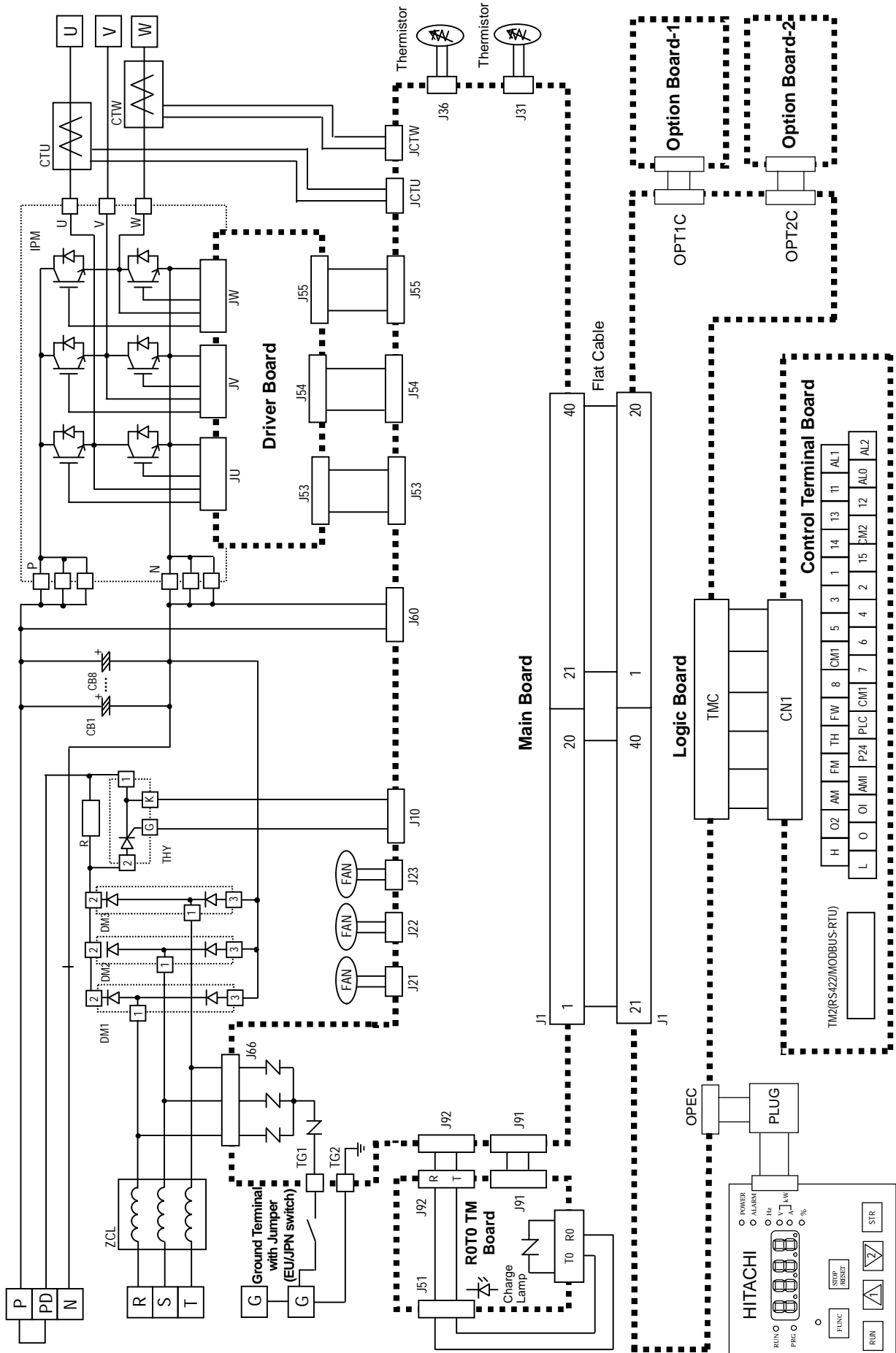

SJ700-055-110HF2 Circuit Diagram**

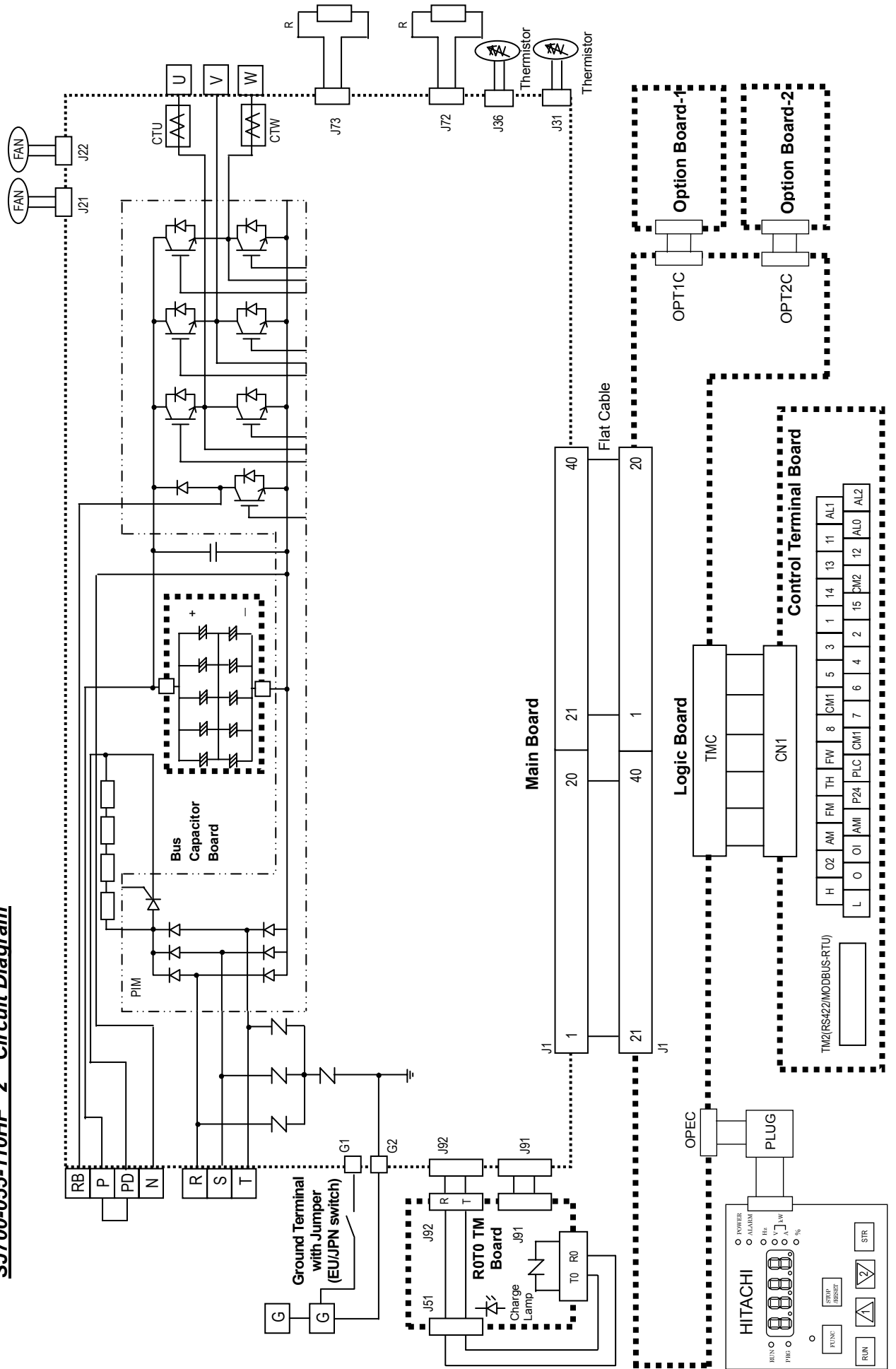

SJ700-150HF2 Circuit Diagram**

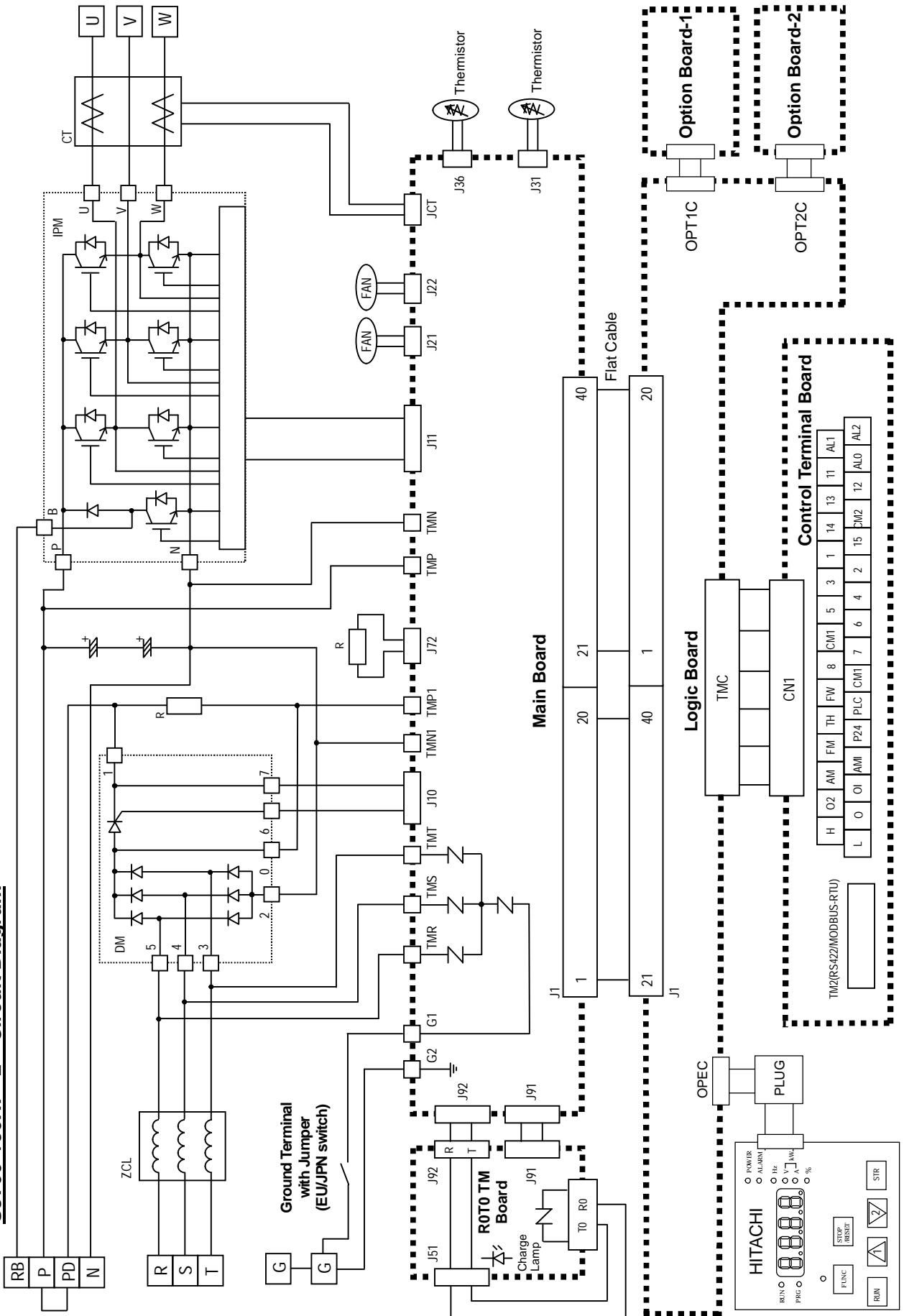

SJ700-185HF2 220HF**2 Circuit Diagram**

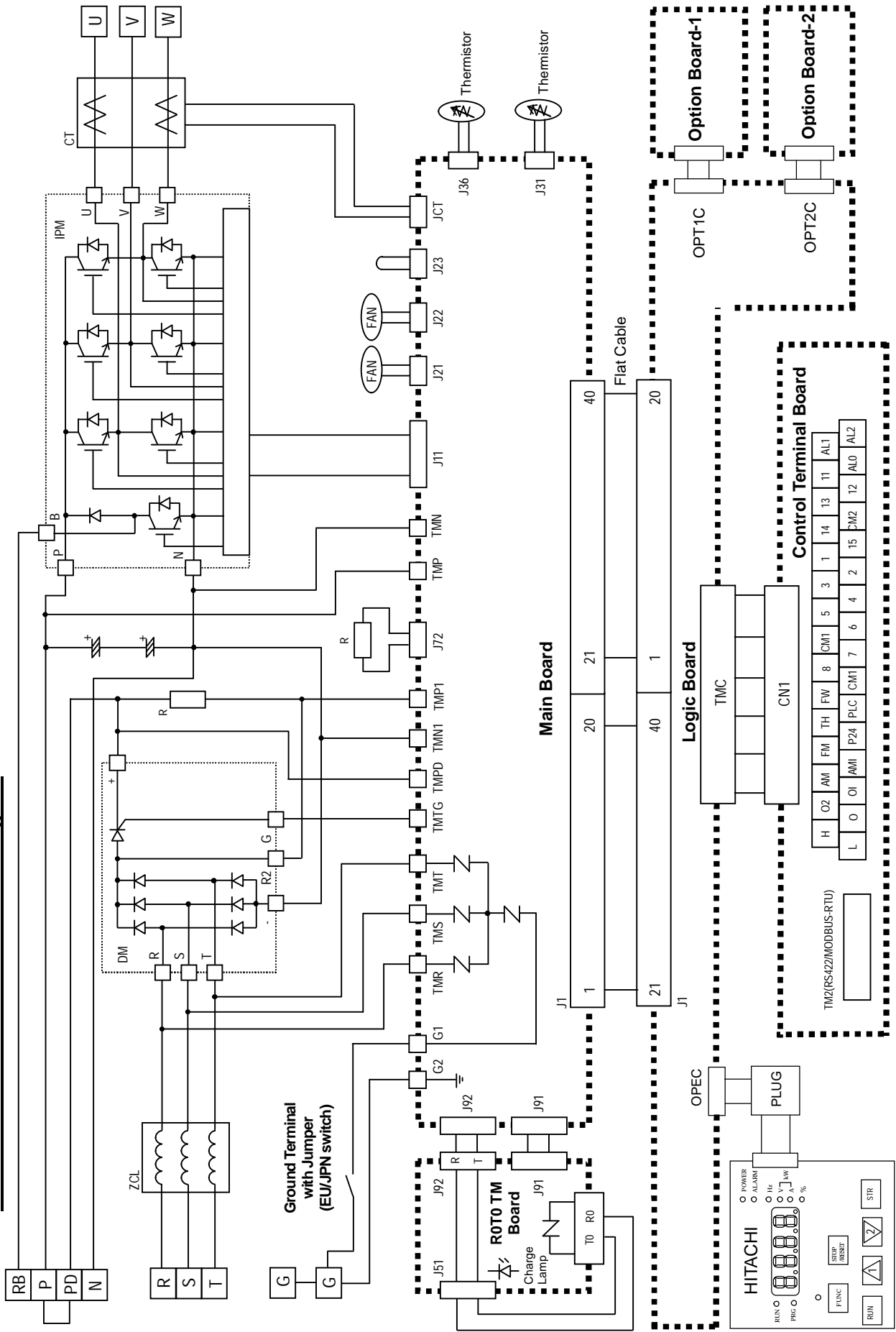

SJ700-300HF2 Circuit Diagram**

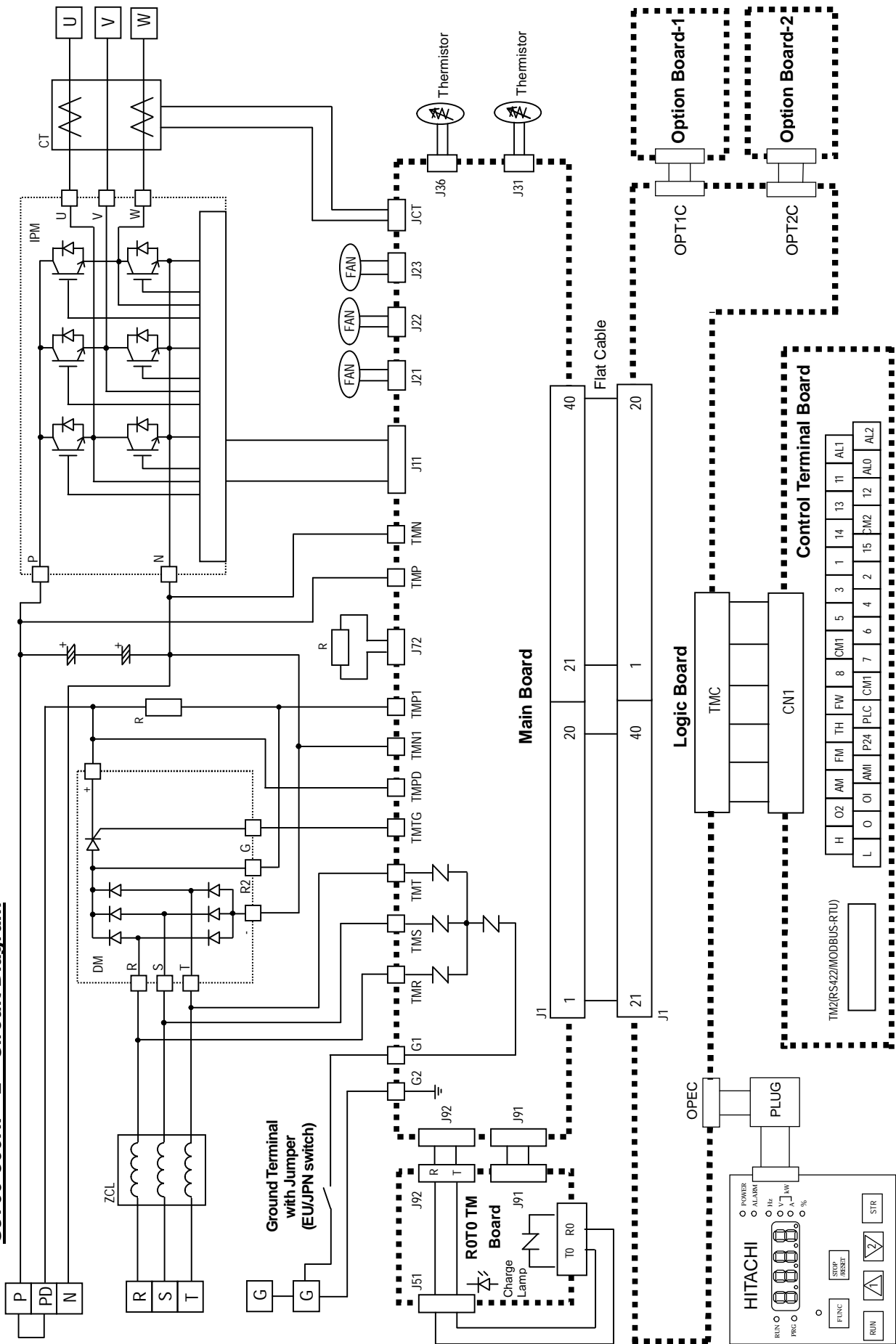

SJ700-370HF**2 Circuit Diagram

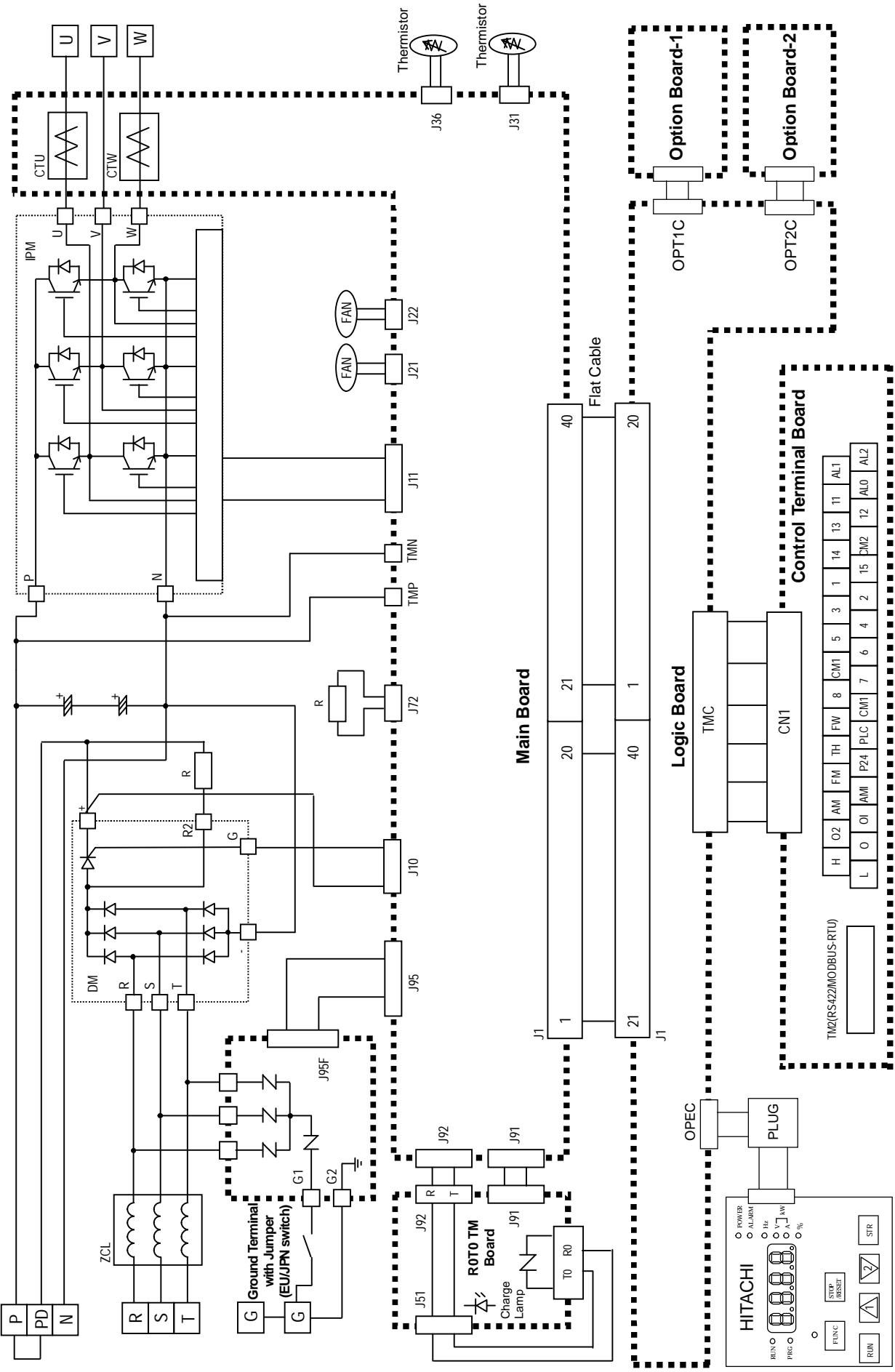

SJ700-450HF2 550HF**2 Circuit Diagram**

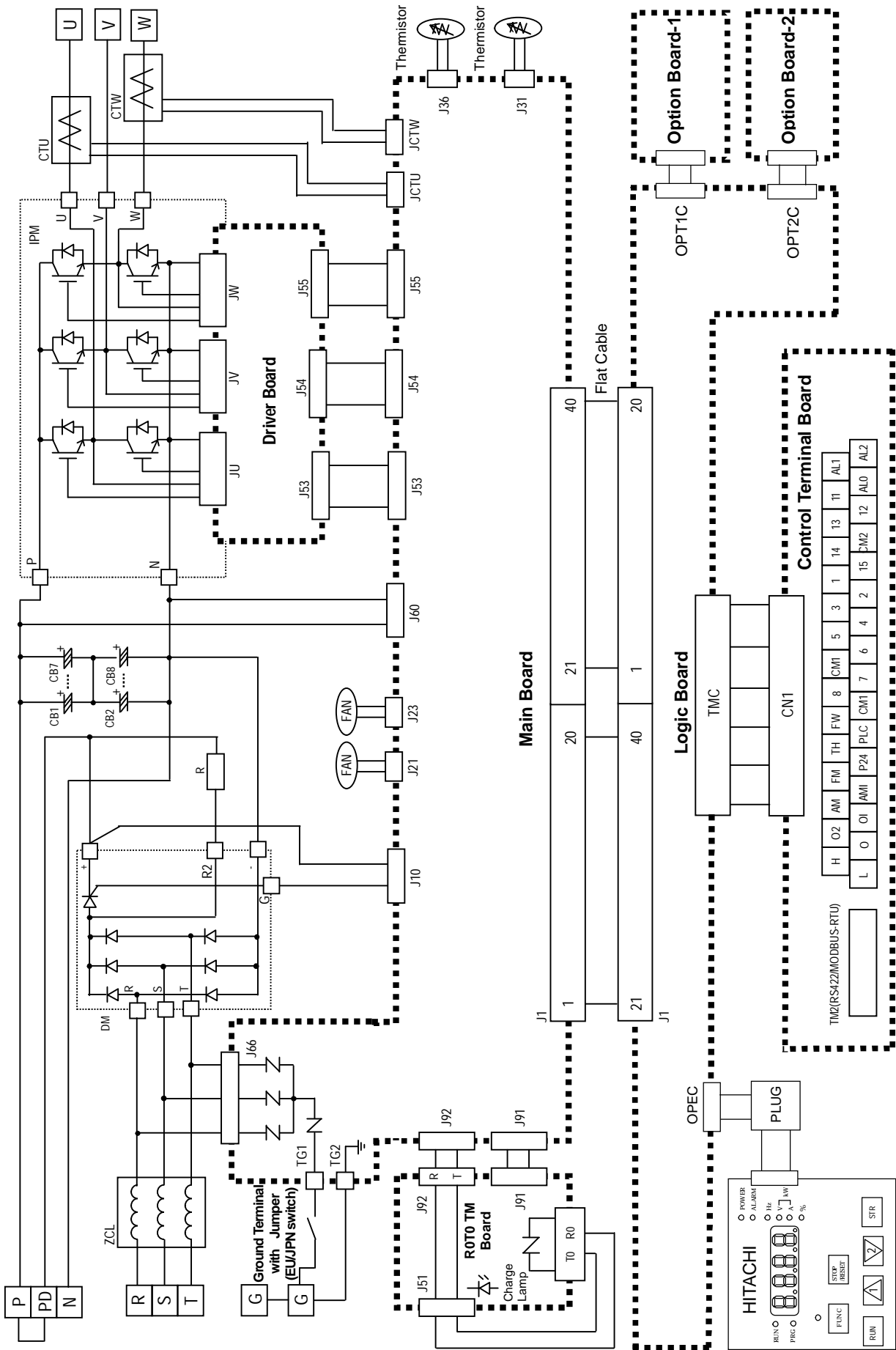

CAD 1 2 3 4 5 6 7 8

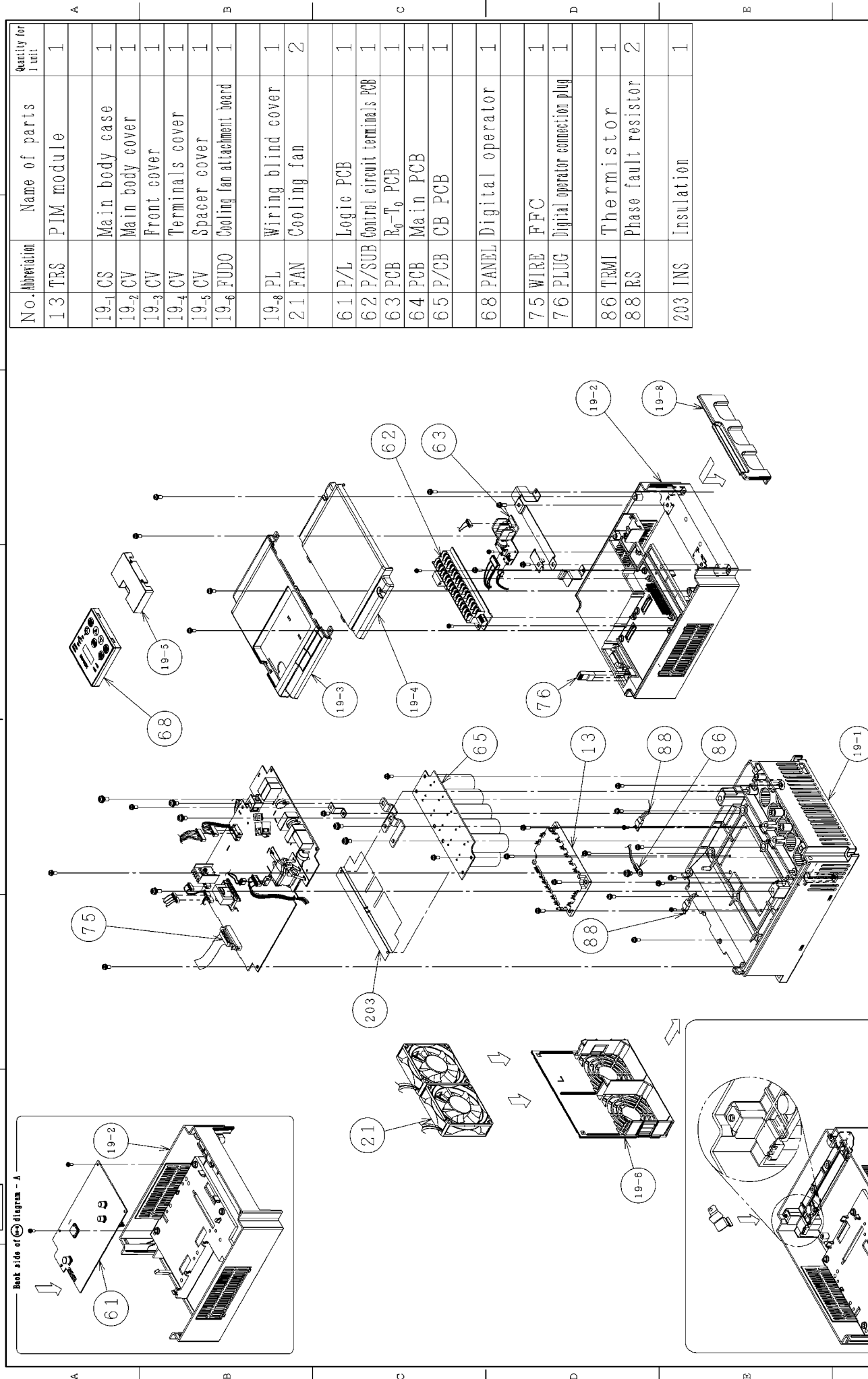

No.	Abbreviation	Name of parts	Quantity for 1 unit
13	TRS	PIM module	1
19-1	CS	Main body case	1
19-2	CV	Main body cover	1
19-3	CV	Front cover	1
19-4	CV	Terminals cover	1
19-5	CV	Spacer cover	1
19-6	FUDO	Cooling fan attachment board	1
19-8	PL	Wiring blind cover	1
21	FAN	Cooling fan	2
61	P/L	Logic PCB	1
62	P/SUB	Control circuit terminals PCB	1
63	PCB	R _v -T ₀ PCB	1
64	PCB	Main PCB	1
65	P/CB	CB PCB	1
68	PANEL	Digital operator	1
75	WIRE	FFC	1
76	PLUG	Digital operator connection plug	1
86	TRMI	Thermistor	1
88	RS	Phase fault resistor	2
203	INS	Insulation	1

御注文 CUSTOMER	数量 QTY. 受注番号 ORDER No.	作業者 WORK No.	REV.
日立製作所	日立		
DRN. T. KANEZAKI	Feb-01-2007	SJ700-055-110LFF2	NARASHINO WORKS DWG. No.
REGD. 2007.08.05	CHD. M. KURITA	Sep-05-2007	Structure diagram
APPD. M. KURITA	Sep-05-2007		Hitachi Industrial Equipment Systems Co., Ltd.
			3243T835145
			SH.
			# FRAME SIZE

Back side of diagram - A

Back side of diagram - B

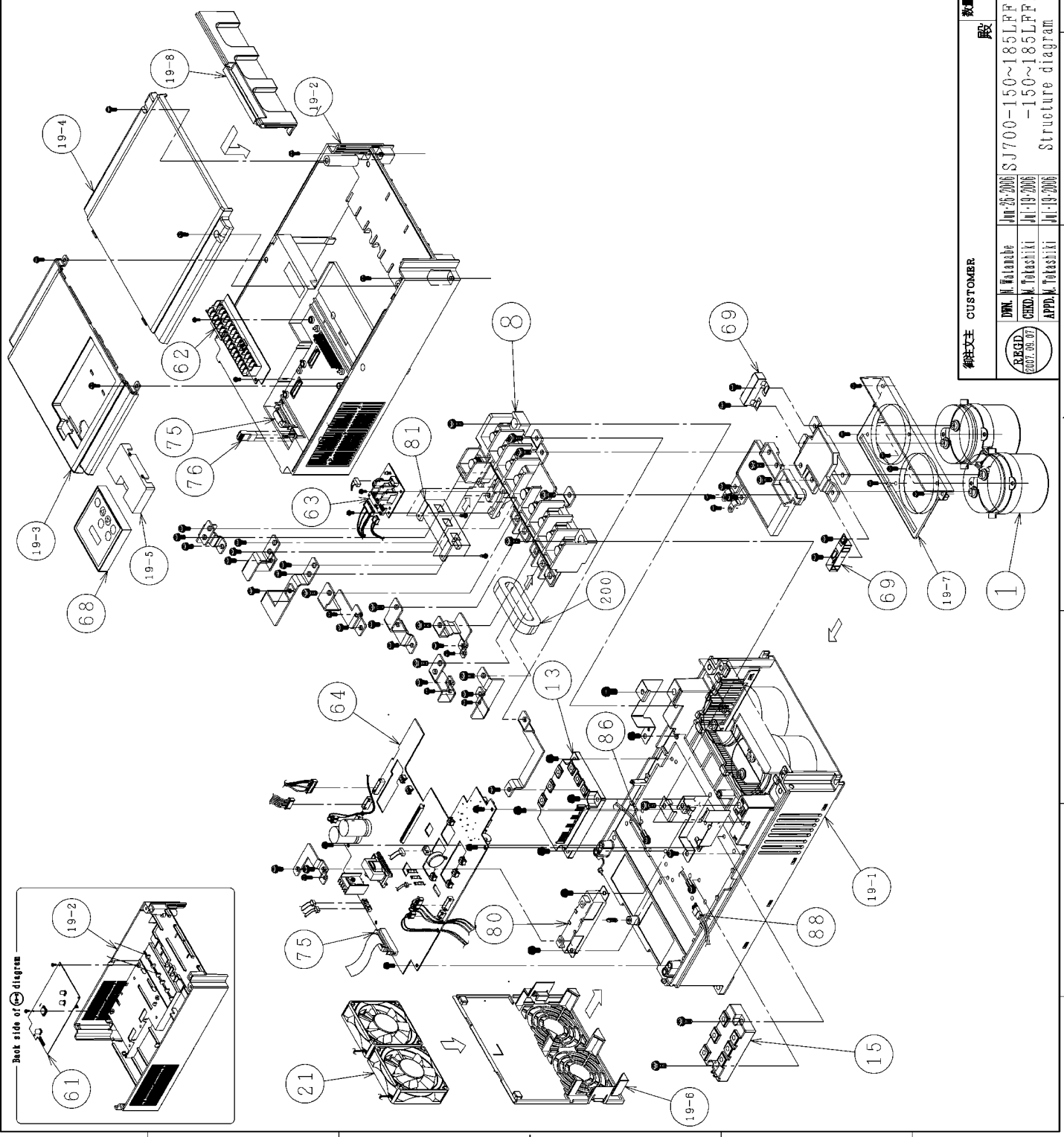

No.	Abbreviation	Name of parts	Quantity for 1 unit
1	CB	DC bus capacitor	2
8	T, BLK	Main circuit terminals	1
13	TRS	IPM module	1
15	DM	Diode module	1
19-1	CS	Main body case	1
19-2	CV	Main body cover	1
19-3	CV	Front cover	1
19-4	CV	Terminals cover	1
19-5	CV	Spacer cover	1
19-6	FUDO	Cooling fan attachment board	1
19-7	PL	DC bus capacitor attachment block	1
19-8	PL	Wiring blind cover	1
21	FAN	Cooling fan	2
61	P/L	Logic PCB	1
62	P/SUB	Control circuit terminals PCB	1
63	PCB	R _g -T _g PCB	1
64	PCB	Main PCB	1
68	PANEL	Digital operator	1
69	RB	Balance resistor	2
75	WIRE	FFC	1
76	PLUG	Digital operator connection plug	1
80	RS	Current-limiting resistor	1
81	CT	Current sensor	1
86	TRMI	Thermistor	2
88	RS	Phase fault resistor	1
200	FIL	Ferrite core	1

数量 QTY.	受注番号 ORDER No.	作業者 WORK No.	REV.
1			2
御注文 CUSTOMER	廠		
DMK. N. Watanabe	Hitachi	NARASHINO WORKS DWG. No.	SH.
REGD. (2007.06.07)	SJ700-150~185LFF	3243T835146	
CHD. K. Takahashi	-150~185LFF2		
APPD. K. Takahashi	Structure diagram		
	#	FRAME SIZE	

CAD

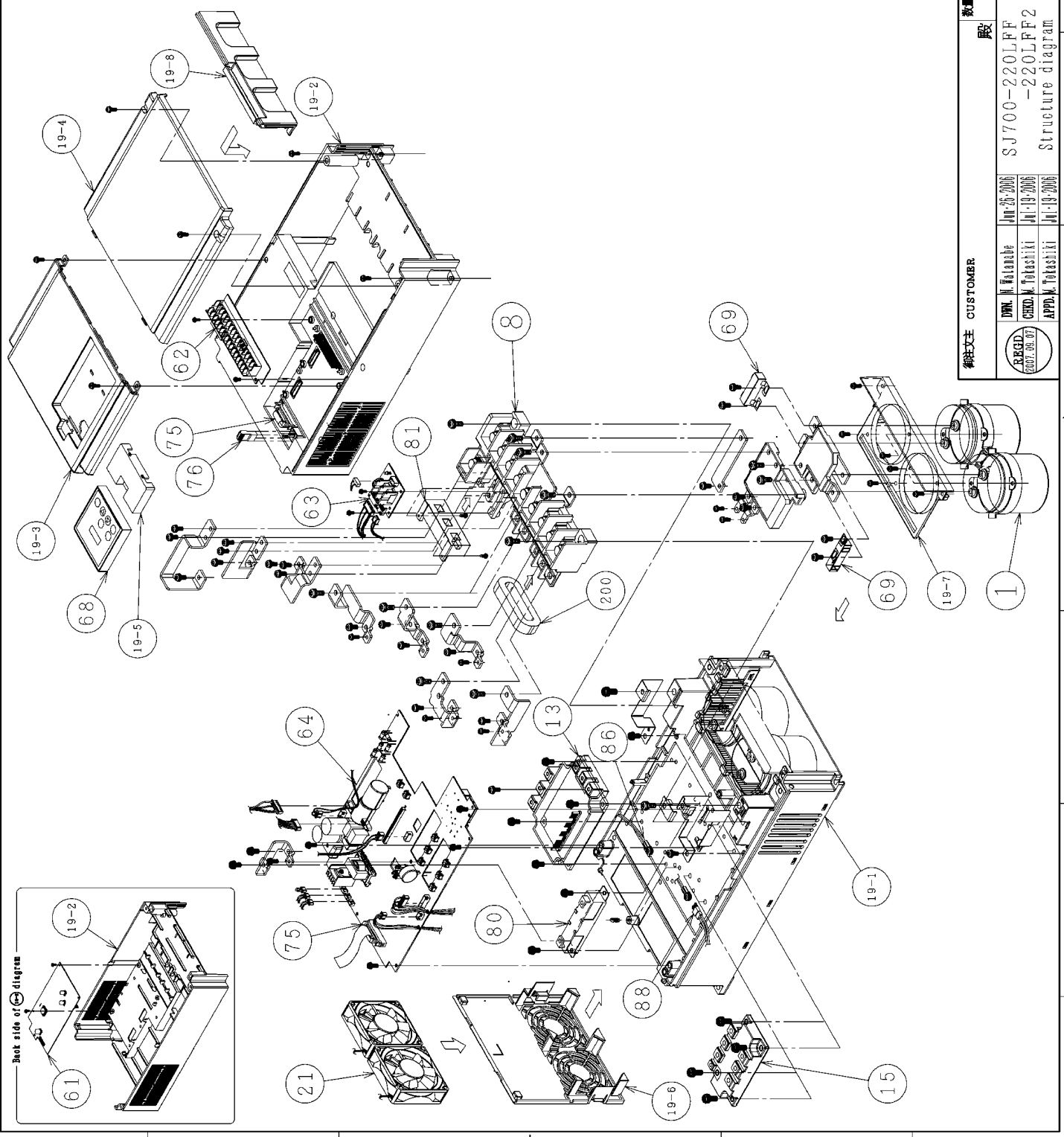

No.	Abbreviation	Name of parts	Quantity for 1 unit
1	CB	DC bus capacitor	2
8	T, BLK	Main circuit terminals	1
13	TRS	IPM module	1
15	DM	Diode module	1
19-1	CS	Main body case	1
19-2	CV	Main body cover	1
19-3	CV	Front cover	1
19-4	CV	Terminals cover	1
19-5	CV	Spacer cover	1
19-6	FUDO	Cooling fan attachment board	1
19-7	PL	DC bus capacitor attachment block	1
19-8	PL	Wiring blind cover	1
21	FAN	Cooling fan	2
61	P/L	Logic PCB	1
62	P/SUB	Control circuit terminals PCB	1
63	PCB	R ₀ -T ₀ PCB	1
64	PCB	Main PCB	1
68	PANEL	Digital operator	1
69	RB	Balance resistor	2
75	WIRE	FFC	1
76	PLUG	Digital operator connection plug	1
80	RS	Current-limiting resistor	1
81	CT	Current sensor	1
86	TRMI	Thermistor	2
88	RS	Phase fault resistor	1
200	FIL	Ferrite core	1

数量 QTY.	受注番号 ORDER No.	作番番号 WORK No.	REV.
1	1	1	2
DATE	DRW. BY	CHKD. BY	APPD. BY
2007.08.07	M. Watanabe	M. Takahashi	M. Takahashi
	DATE	DATE	DATE
	2006.06.06	2006.07.19	2006.07.19
顧客名 CUSTOMER	数量 QTY.	受注番号 ORDER No.	作番番号 WORK No.
Hitachi Industrial Equipment Systems Co., Ltd.	1	1	1
	DATE	DATE	DATE
	2006.06.06	2006.07.19	2006.07.19
納品先	品名	数量	REV.
	SJ700-220LFF	1	2
	-220LFF2	1	
	Structure diagram		
	3243T835147		
	FRAME SIZE		

CAD 1 2 3 4 5 6 7 8

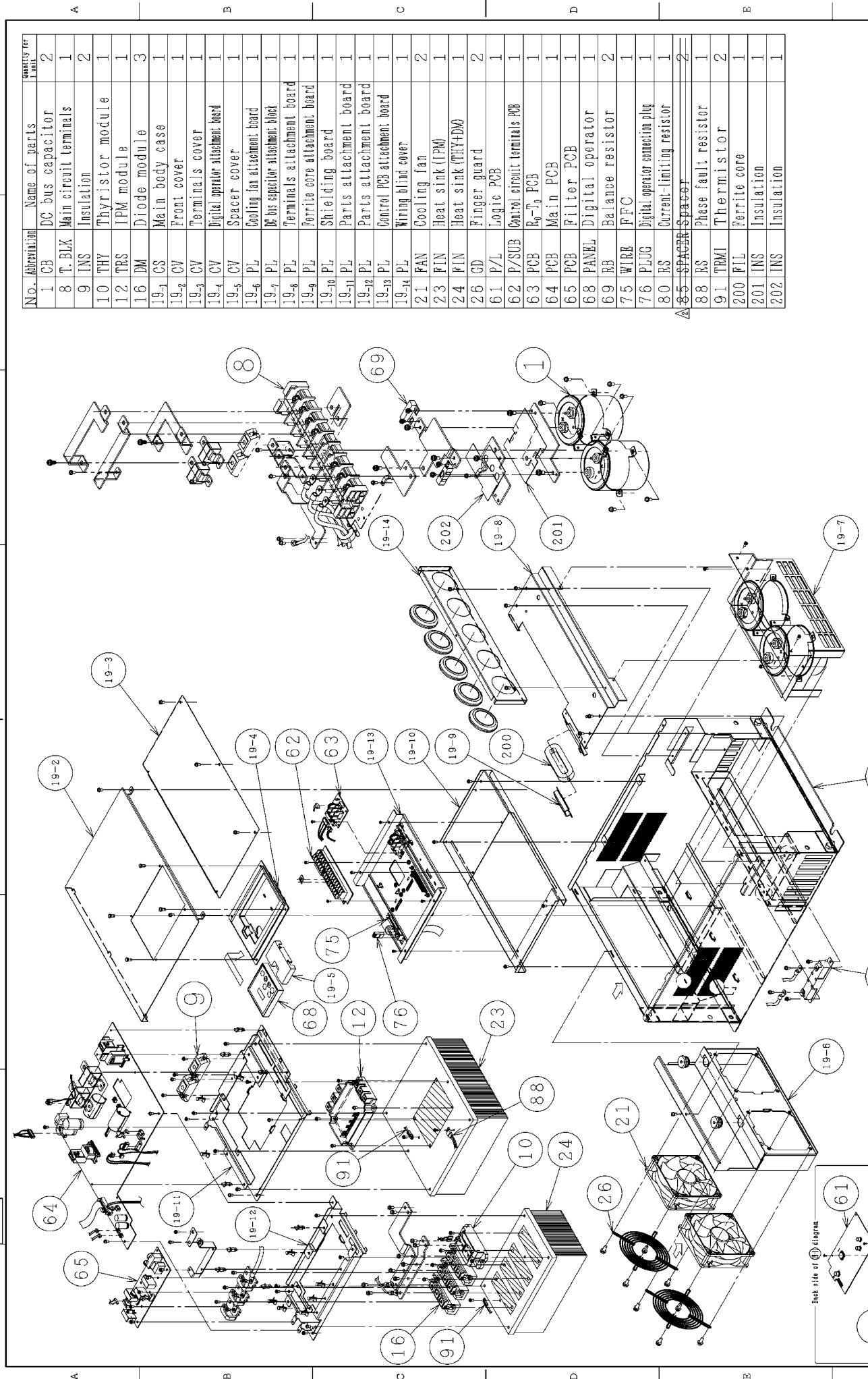

No.	Abbreviation	Name of parts	QUANTITY OF 1 UNIT
1	CB	DC bus capacitor	2
8	T. BLX	Main circuit terminals	1
9	INS	Insulation	2
10	THY	Thyristor module	1
12	TRM	IPM module	1
16	DM	Diode module	3
19-1	CS	Main body case	1
19-2	CV	Front cover	1
19-3	CV	Terminals cover	1
19-4	CV	Digital operator attachment board	1
19-5	CV	Spacer cover	1
19-6	PL	Cooling fan attachment board	1
19-7	PL	DC bus separator attachment block	1
19-8	PL	Terminals attachment board	1
19-9	PL	Ferrite core attachment board	1
19-10	PL	Shielding board	1
19-11	PL	Parts attachment board	1
19-12	PL	Parts attachment board	1
19-13	PL	Control PCB attachment board	1
19-14	PL	Wiring blind cover	1
21	FAN	Cooling fan	2
23	FIN	Heat sink (IPM)	1
24	FIN	Heat sink (THY+DM)	1
26	GD	Finger guard	2
61	P/L	Logic PCB	1
62	P/SUB	Control circuit terminals PCB	1
63	PCB	R ₀ -I ₀ PCB	1
64	PCB	Main PCB	1
65	PCB	Filter PCB	1
68	PANEL	Digital operator	1
69	RB	Balance resistor	2
75	W/BB	FFC	1
76	PLUG	Digital operator connection plug	1
80	RS	Current-limiting resistor	1
88	RS	Phase fault resistor	2
91	TRM1	Thermistor	1
200	FL	Ferrite core	1
201	INS	Insulation	1
202	INS	Insulation	1

御注文 CUSTOMER 数量 QTY. 受注番号 ORDER No. 株式会社 日立製作所

REGD. 2007.06.07
 DMK. M. Watanabe JAN. 19. 2006
 CHDK. K. Takahashi JAN. 19. 2006
 APD. K. Takahashi JAN. 19. 2006

SUJ700-370LFFP
 -370LFFP2
 Structure diagram
 Hitachi Industrial Equipment Systems Co., Ltd.
 MARASHINO WORKS DWG. No. 3243T835149
 REV. 2
 SE.
 # FRAME SIZE

Δ: 07/Sep/6 Revised. Removed spacers.

CAD

1 2 3 4 5 6 7 8

A B C D E F

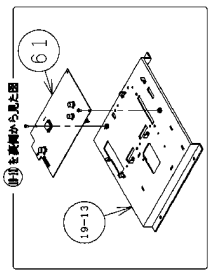
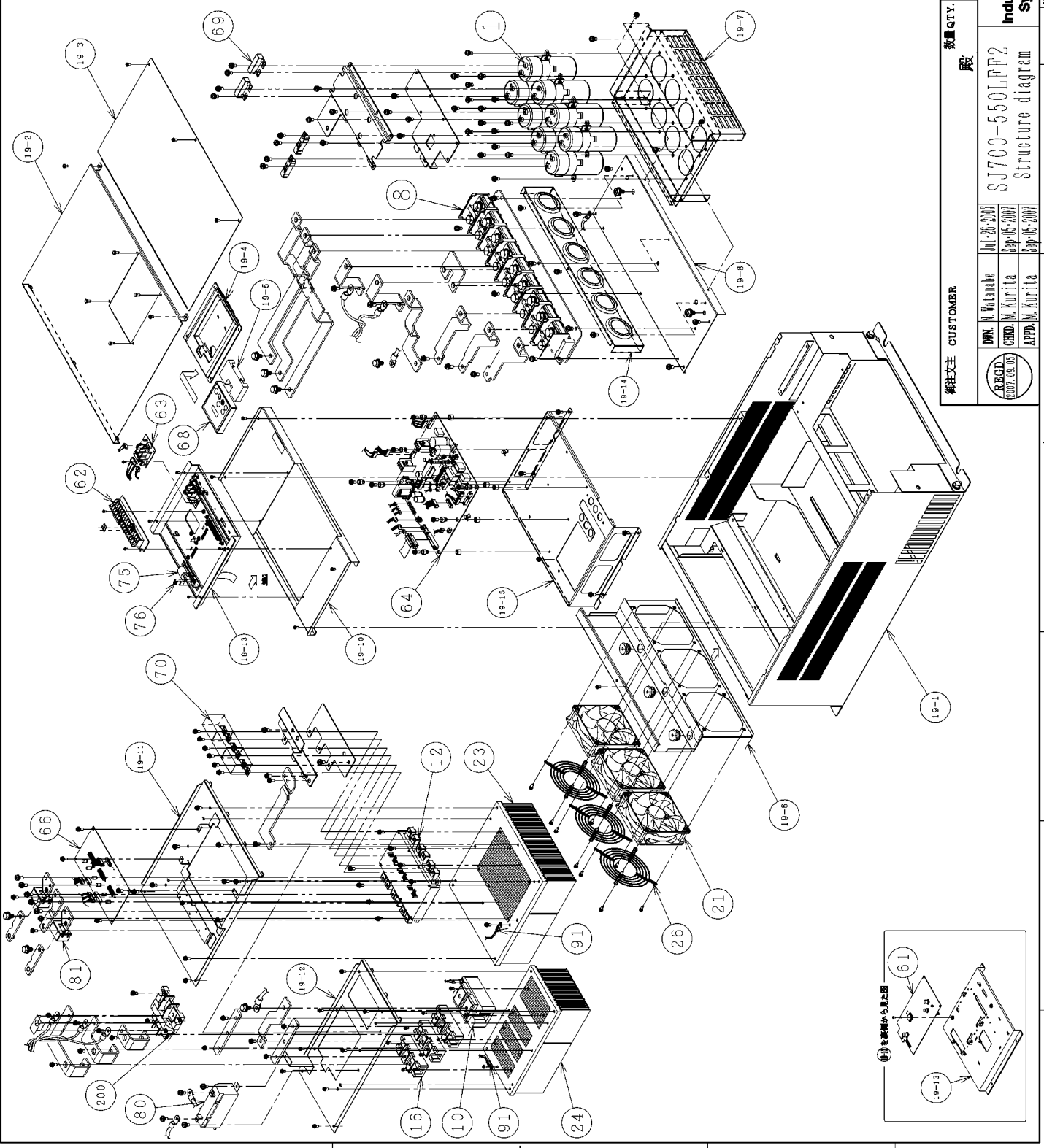

No.	Abbreviation	Name of parts	QUANTITY OF 1 UNIT
1	CB	DC bus capacitor	8
8	T. BLX	Main circuit terminals	1
10	THY	Thyristor module	1
12	TBS	IPM module	1
16	DM	Diode module	3
19-1	CS	Main body case	1
19-2	CV	Front cover	1
19-3	CV	Terminals cover	1
19-4	CV	Digital operator attachment board	1
19-5	CV	Spacer cover	1
19-6	PL	Cooling fan attachment board	1
19-7	PL	DC bus capacitor attachment block	1
19-8	PL	Terminals attachment board	1
19-9	PL	Shielding board	1
19-10	PL	Parts attachment board	1
19-11	PL	Parts attachment board	1
19-12	PL	Parts attachment board	1
19-13	PL	Control PCB attachment board	1
19-14	PL	Wiring blind cover	1
19-15	PL	Main PCB attachment plate	1
21	FAN	Cooling fan	3
23	FIN	Heat sink (IPM)	1
24	FIN	Heat sink (FHV+DM)	1
26	GD	Finger guard	3
61	P/L	Logic PCB	1
62	P/SUB	Control circuit terminals PCB	1
63	PCB	R ₀₋₁ PCB	1
64	PCB	Main PCB	1
66	PCB	Driver PCB	1
68	PANEL	Digital operator	1
69	RB	Balance resistor	4
70	C	Sunbeber capacitor	3
75	WIRE	FFC	1
76	PLUG	Digital operator connection plug	1
80	RS	Current-limiting resistor	1
81	CT	Current sensor	2
91	TRM	Thermistor	2
200	FL	Ferrite core	1
201	INS	Insulation	1

御注文 CUSTOMER 数量 QTY. 受注番号 ORDER No. 作業者 WORK No. REV.

日立 Hitachi Industrial Equipment Systems Co., Ltd. MARASHINO WORKS DWG. No. SH.

SJ700-550LFP2 Structure diagram 3243T835151

REGD. 2007.08.05 2007.08.05 2007.08.05 2007.08.05

DMK. M. Watanabe 2007.08.05
 CHD. M. Kurita 2007.08.05
 APP. M. Kurita 2007.08.05

FRAME SIZE

CAD 1 2 3 4 5 6 7 8

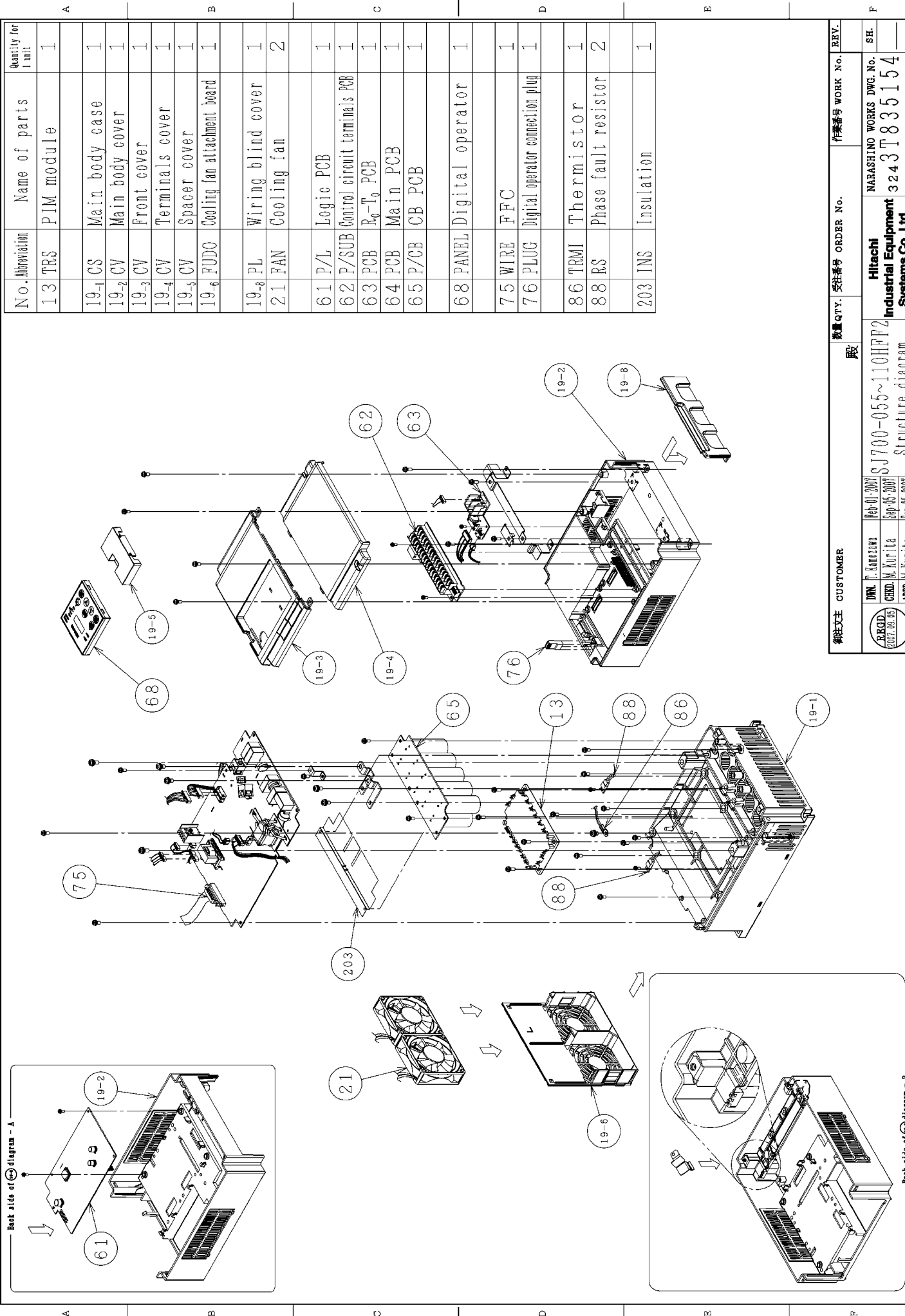

No.	Abbreviation	Name of parts	Quantity for 1 unit
13	TRS	PIM module	1
19-1	CS	Main body case	1
19-2	CV	Main body cover	1
19-3	CV	Front cover	1
19-4	CV	Terminals cover	1
19-5	CV	Spacer cover	1
19-6	FUDO	Cooling fan attachment board	1
19-8	PL	Wiring blind cover	1
21	FAN	Cooling fan	2
61	P/L	Logic PCB	1
62	P/SUB	Control circuit terminals PCB	1
63	PCB	R _v -T ₀ PCB	1
64	PCB	Main PCB	1
65	P/CB	CB PCB	1
68	PANEL	Digital operator	1
75	WIRE	FFC	1
76	PLUG	Digital operator connection plug	1
86	TRMI	Thermistor	1
88	RS	Phase fault resistor	2
203	INS	Insulation	1

御注文 CUSTOMER	数量 QTY.	受注番号 ORDER No.	作務番号 WORK No.	REV.
REGD. 2007.08.05	DRN. T. KANEZAKI	Feb-01-2007	SJ700-055-110HFP2	NARASHINO WORKS DWG. No.
	CHD. M. KURITA	Sep-05-2007	Structure diagram	SH.
	APP. M. KURITA	Sep-05-2007		3243T835154
			#	FRAME SIZE

Back side of diagram - A

Back side of diagram - B

CAD

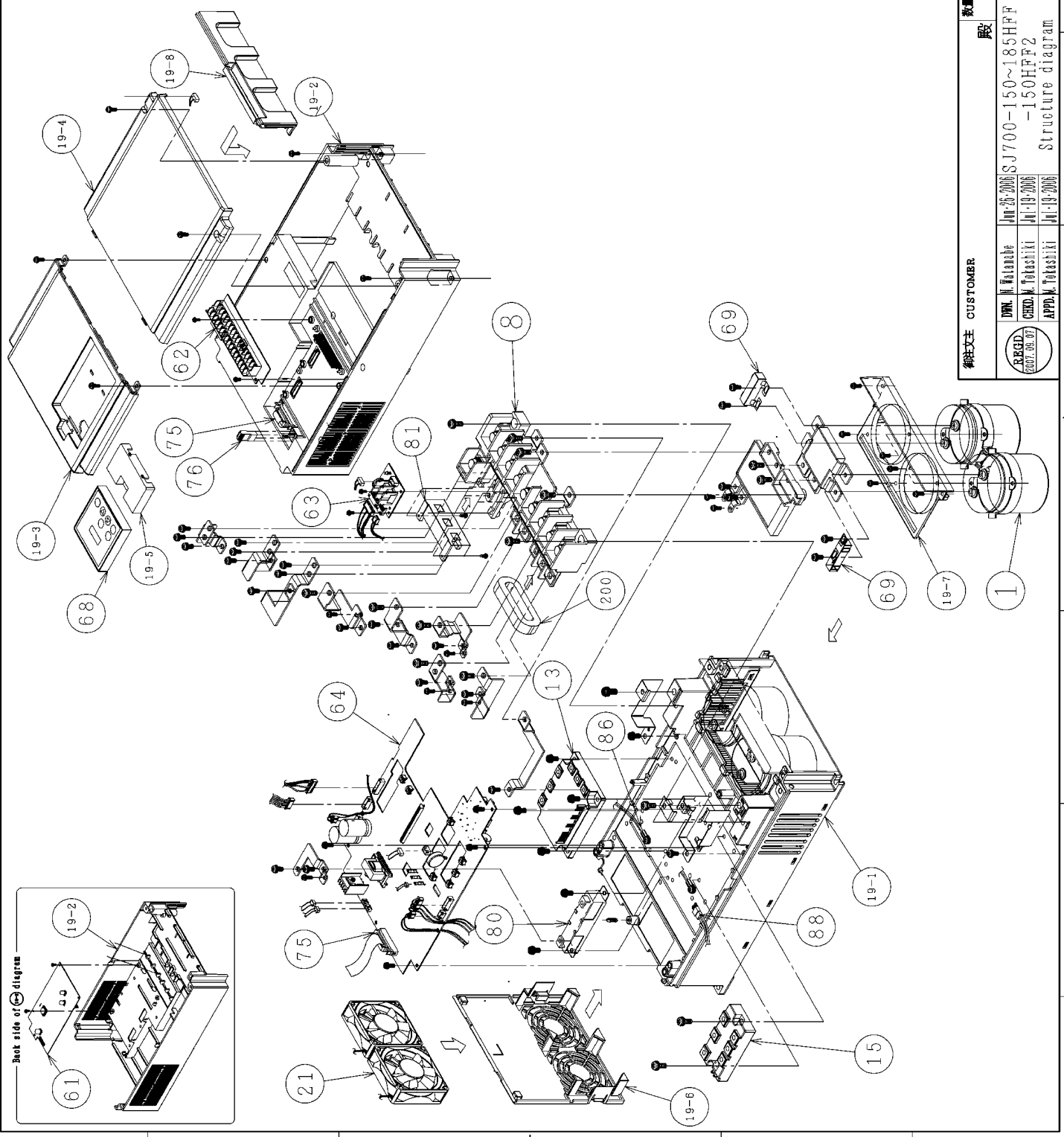

No.	Abbreviation	Name of parts	Quantity for 1 unit
1	CB	DC bus capacitor	2
8	T, BLK	Main circuit terminals	1
13	TRS	IPM module	1
15	DM	Diode module	1
19-1	CS	Main body case	1
19-2	CV	Main body cover	1
19-3	CV	Front cover	1
19-4	CV	Terminals cover	1
19-5	CV	Spacer cover	1
19-6	FUDO	Cooling fan attachment board	1
19-7	PL	DC bus capacitor attachment block	1
19-8	PL	Wiring blind cover	1
21	FAN	Cooling fan	2
61	P/L	Logic PCB	1
62	P/SUB	Control circuit terminals PCB	1
63	PCB	R _g -T _g PCB	1
64	PCB	Main PCB	1
68	PANEL	Digital operator	1
69	RB	Balance resistor	2
75	WIRE	FFC	1
76	PLUG	Digital operator connection plug	1
80	RS	Current-limiting resistor	1
81	CT	Current sensor	1
86	TRMI	Thermistor	2
88	RS	Phase fault resistor	1
200	FIL	Ferrite core	1

数量 QTY.	受注番号 ORDER No.	作業者 WORK No.	REV.
1	1	1	2
御注文 CUSTOMER	限 股		
DM: N. Watanabe	REV. 2006	SJ700-150-185HFF	
CHKD: K. Takahashi	REV. 2006	-150HFF2	
APPD: K. Takahashi	REV. 2006	Structure diagram	
Hitachi Industrial Equipment Systems Co., Ltd.		NARASHINO WORKS	DWG. No.
			3243T835155
		#	FRAME SIZE

CAD

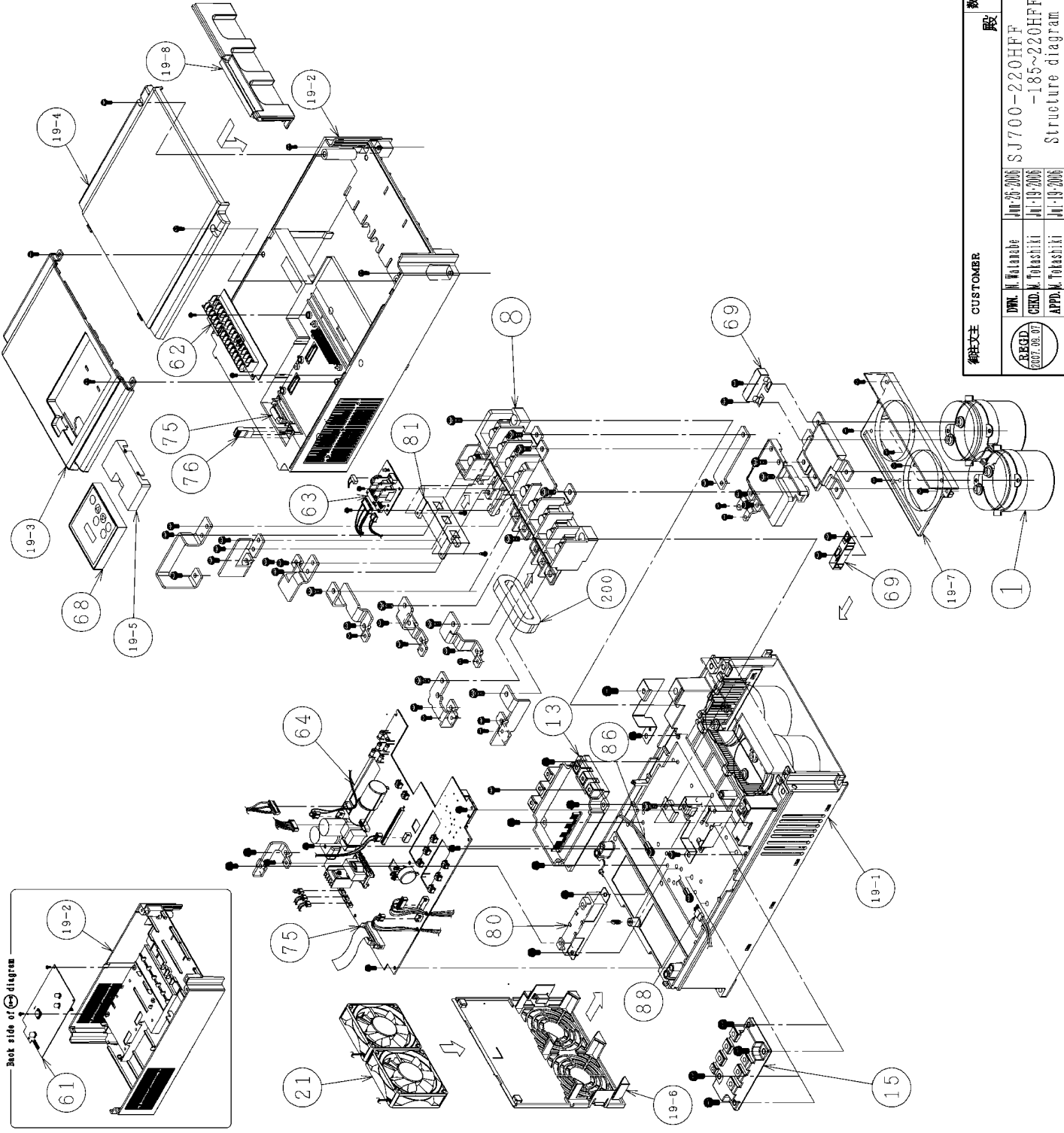

No.	Abbreviation	Name of parts	Quantity for 1 unit
1	CB	DC bus capacitor	2
8	T, BLK	Main circuit terminals	1
13	TRS	IPM module	1
15	DM	Diode module	1
19-1	CS	Main body case	1
19-2	CV	Main body cover	1
19-3	CV	Front cover	1
19-4	CV	Terminals cover	1
19-5	CV	Spacer cover	1
19-6	FUDO	Cooling fan attachment board	1
19-7	PL	DC bus capacitor attachment block	1
19-8	PL	Wiring blind cover	1
21	FAN	Cooling fan	2
61	P/L	Logic PCB	1
62	P/SUB	Control circuit terminals PCB	1
63	PCB	R ₀ -T ₀ PCB	1
64	PCB	Main PCB	1
68	PANEL	Digital operator	1
69	RB	Balance resistor	2
75	WIRE	FFC	1
76	PLUG	Digital operator connection plug	1
80	RS	Current-limiting resistor	1
81	CT	Current sensor	1
86	TRMI	Thermistor	2
88	RS	Phase fault resistor	1
200	FIL	Ferrite core	1

数量 QTY.	受注番号 ORDER No.	作番番号 WORK No.	REV.
1	1	1	2
御注文 CUSTOMER	限 股		
DM: N. Watanabe	DATE: 2006	SJ700-220HFF	
CHKD: K. Takahashi	DATE: 2006	-185~220HFF2	
APPD: K. Takahashi	DATE: 2006	Structure diagram	
REGD. 2007.08.07			
Hitachi Industrial Equipment Systems Co., Ltd.		NARASHINO WORKS DWG. No.	SH.
		3243T835156	
		# FRAME SIZE	

CAD

1 2 3 4 5 6 7 8

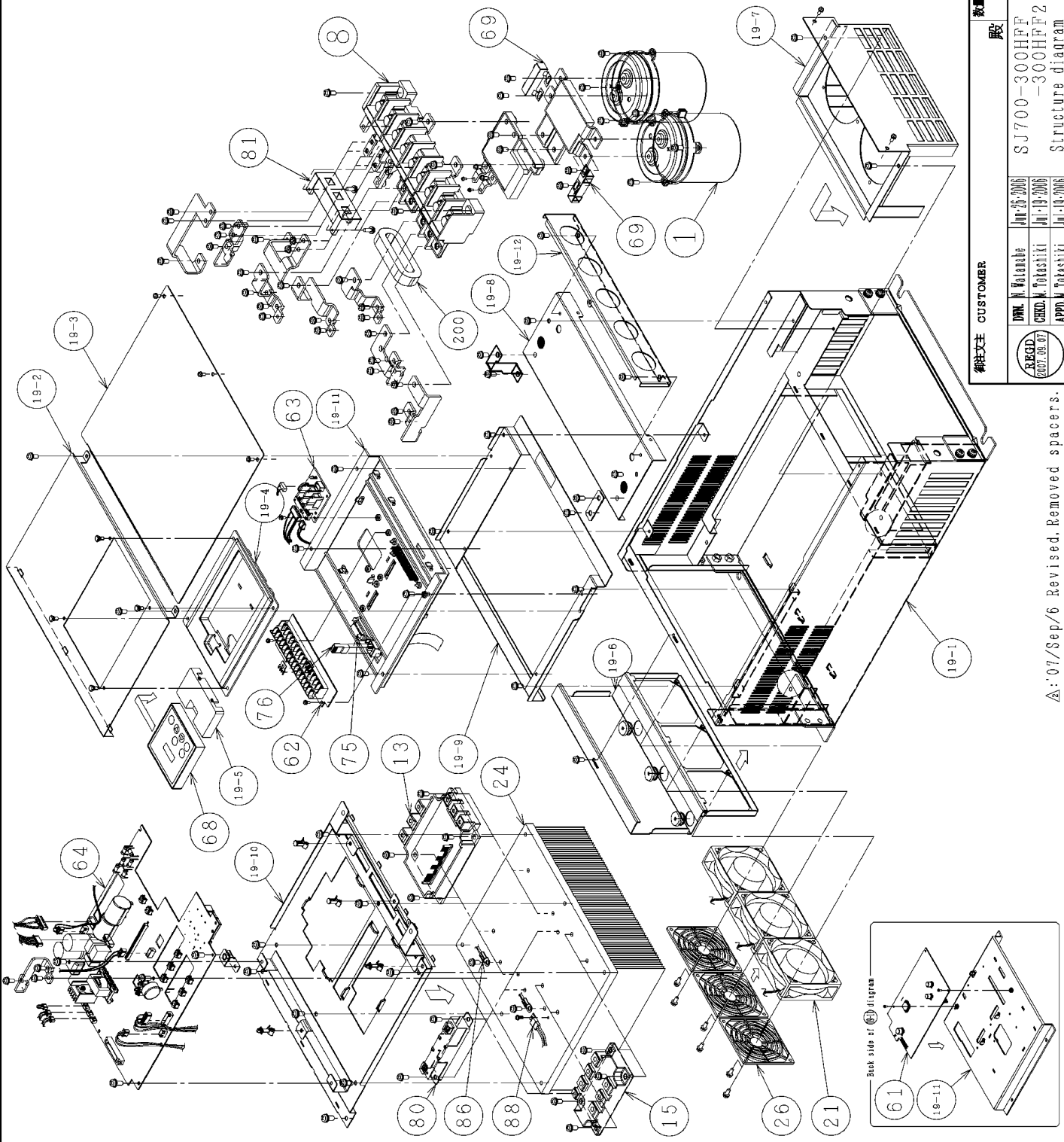

No.	Abbreviation	Name of parts	Quantity for 1 unit
1	CB	DC bus capacitor	2
8	T. BLK	Main circuit terminals	1
13	TRS	IPM module	1
15	DM	Diode module	1
19-1	CS	Main body case	1
19-2	CV	Front cover	1
19-3	CV	Terminals cover	1
19-4	CV	Digital operator attachment board	1
19-5	CV	Spacer cover	1
19-6	PL	Cooling fan attachment board	1
19-7	PL	DC bus capacitor attachment block	1
19-8	BGD	Terminals attachment board	1
19-9	PL	Shielding board	1
19-10	PL	Parts attachment board	1
19-11	PL	Control PCB attachment board	1
19-12	PL	Wiring blind cover	1
21	FAN	Cooling fan	3
24	FIN	Heat sink	1
26	GD	Finger guard	3
61	P/L	Logic PCB	1
62	P/SUB	Control circuit terminals PCB	1
63	PCB	R _g -T _g PCB	1
64	PCB	Main PCB	1
68	PANEL	Digital operator	1
69	RB	Balance resistor	2
75	WIRE	FFC	1
76	PLUG	Digital operator connection plug	1
80	RS	Current-limiting resistor	1
81	CT	Current-sensor	1
83	SPACER	Spacer	2
86	TRMI	Thermistor	2
88	RS	Phase fault resistor	1
200	PIL	Ferrite core	1

数量 QTY.	受注番号 ORDER No.	作務番号 WORK No.	REV.
			2
御注文 CUSTOMER	廠		
 Hitachi Industrial Equipment Systems Co., Ltd.	MARASHINO WORKS DWG. No. 3243T835157		SH.
訂入 訂入 訂入 DATE: 2007.08.07 DRAWN BY: Watanabe CHECKED BY: Takahashi APPROVED BY: Takahashi	SJ700-300HFF -300HFF2 Structure diagram		
Δ: '07/Sep/6 Revised. Removed spacers.			
# FRAME SIZE			

1 2 3 4 5 6 7 8

CAD

1 2 3 4 5 6 7 8

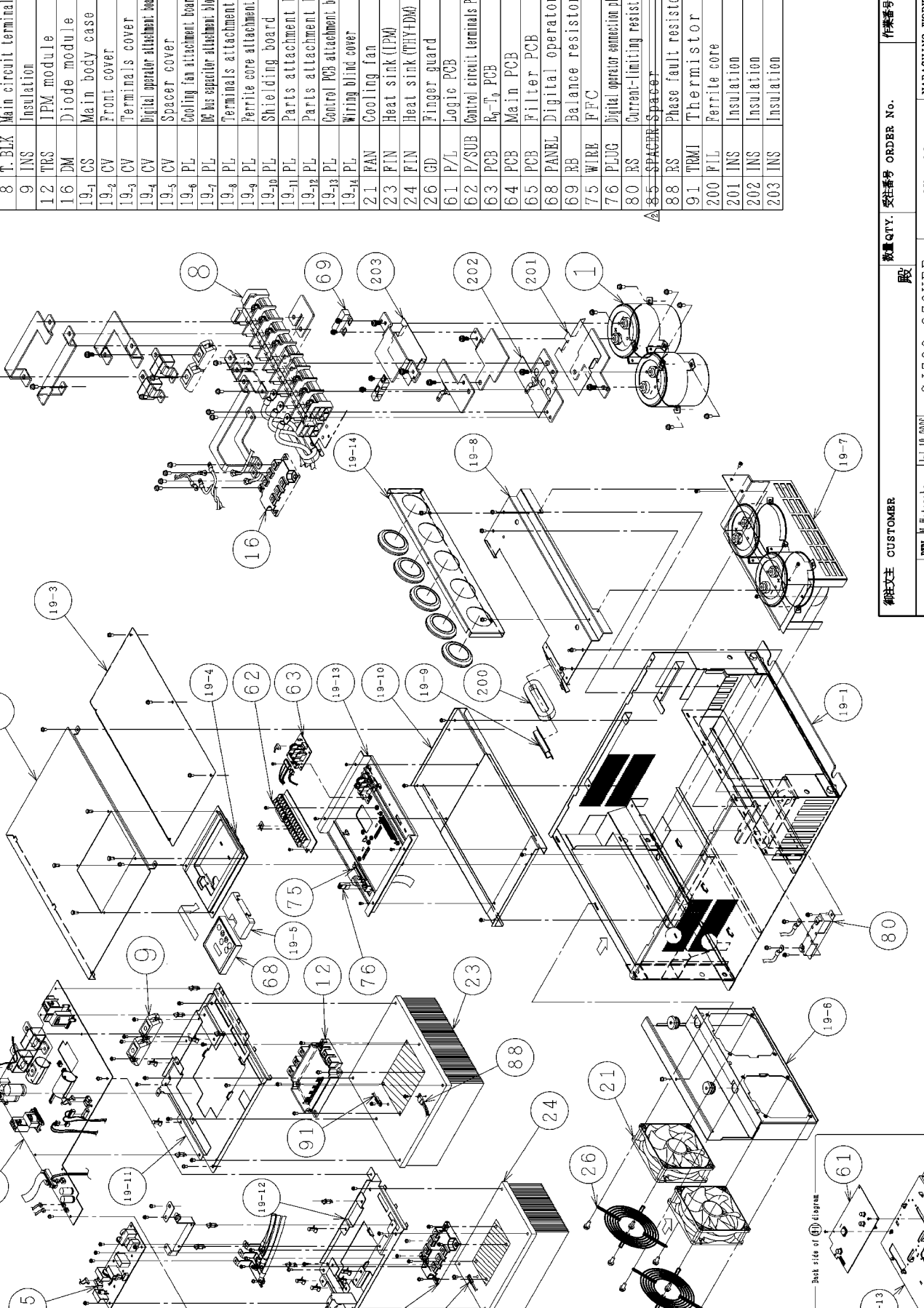

No.	Abbreviation	Name of parts	QUANTITY OF 1 UNIT
1	CB	DC bus capacitor	2
8	T. BLX	Main circuit terminals	1
9	INS	Insulation	2
12	TBS	IPM module	1
16	DM	Diode module	1
19-1	CS	Main body case	1
19-2	CV	Front cover	1
19-3	CV	Terminals cover	1
19-4	CV	Digital operator attachment board	1
19-5	CV	Spacer cover	1
19-6	PL	Cooling fan attachment board	1
19-7	PL	DC bus capacitor attachment block	1
19-8	PL	Terminals attachment board	1
19-9	PL	Ferrite core attachment board	1
19-10	PL	Shielding board	1
19-11	PL	Parts attachment board	1
19-12	PL	Parts attachment board	1
19-13	PL	Control PCB attachment board	1
19-14	PL	Wiring blind cover	1
21	FAN	Cooling fan	2
23	FIN	Heat sink (IPM)	1
24	FIN	Heat sink (PHV+DM)	1
26	GD	Finger guard	2
61	P/L	Logic PCB	1
62	P/SUB	Control circuit terminals PCB	1
63	PCB	R ₀₋₁ PCB	1
64	PCB	Main PCB	1
65	PCB	Filter PCB	1
68	PANEL	Digital operator	1
69	RB	Balance resistor	2
75	WIRE	PFC	1
76	PLUG	Digital operator connection plug	1
80	RS	Current-limiting resistor	1
85	SPACER	Spacer	2
88	RS	Phase fault resistor	1
91	TRM1	Thermistor	2
200	FIL	Ferrite core	1
201	INS	Insulation	1
202	INS	Insulation	1
203	INS	Insulation	1

数量 QTY.	受注番号 ORDER No.	作業者 WORK No.	REV.
1	3243T835158	2	2

御注文 CUSTOMER	数量 QTY.	受注番号 ORDER No.	作業者 WORK No.
HITACHI	1	3243T835158	2

REGD. 2007.08.07	DATE JAN-19-2006	REV. JAN-19-2006	DATE JAN-19-2006
APPRO. M. Takahashi	CHKD. M. Takahashi	APPRO. M. Takahashi	CHKD. M. Takahashi

△: '07/Sep/6 Revised. Removed spacers.

1 2 3 4 5 6 7 8

A B C D E F

Hitachi Industrial Equipment Systems Co., Ltd. MARASHINO WORKS DWG. No. 3243T835158

Structure diagram

FRAME SIZE

CAD 1 2 3 4 5 6 7 8

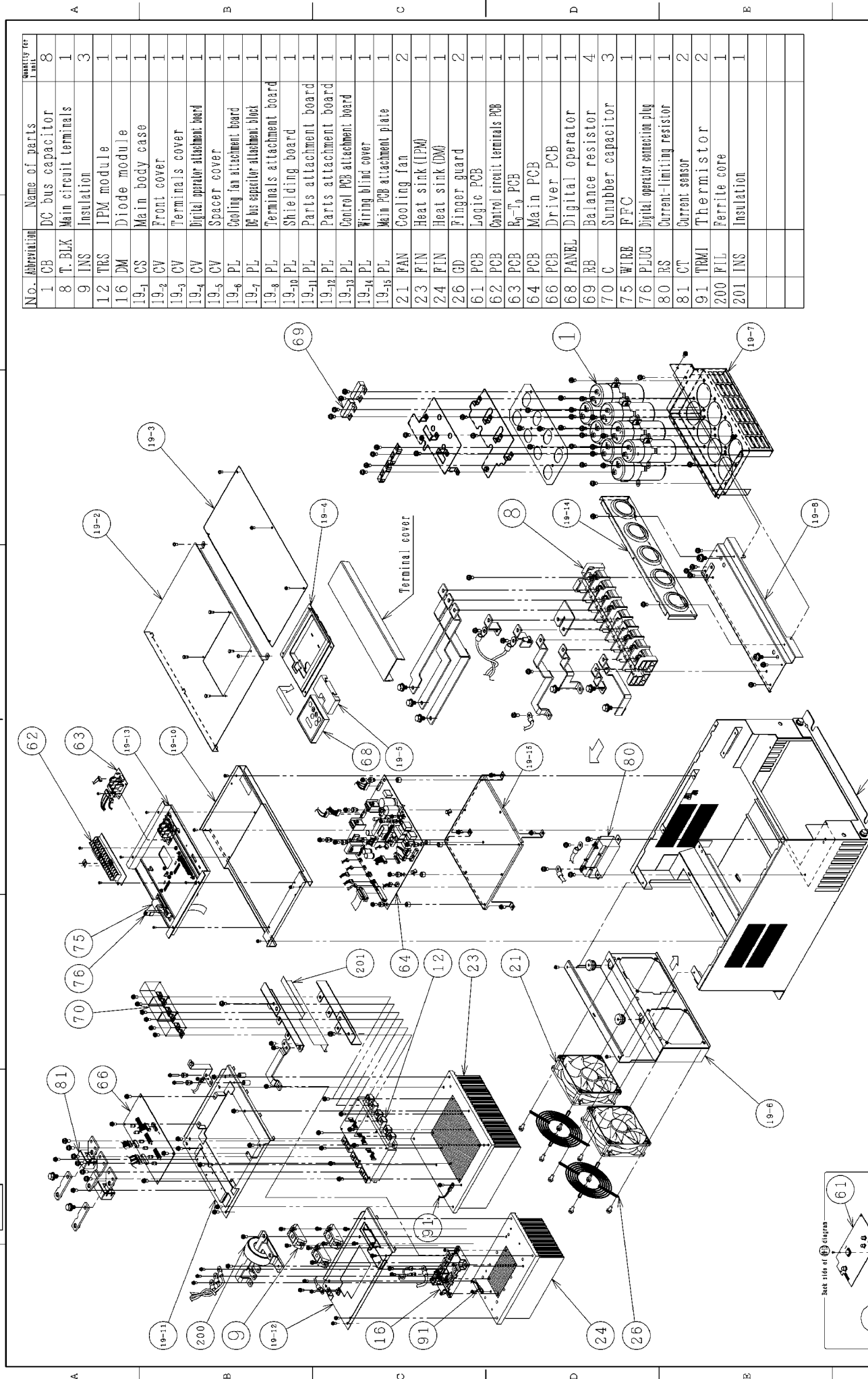

No.	Abbreviation	Name of parts	QUANTITY OF 1 UNIT
1	CB	DC bus capacitor	8
8	T.BLX	Main circuit terminals	1
9	INS	Insulation	3
12	TMS	IPM module	1
16	DM	Diode module	1
19-1 CS		Main body case	1
19-2 CV		Front cover	1
19-3 CV		Terminals cover	1
19-4 CV		Digital operator attachment board	1
19-5 CV		Spacer cover	1
19-6 PL		Cooling fan attachment board	1
19-7 PL		DC bus capacitor attachment block	1
19-8 PL		Terminals attachment board	1
19-10 PL		Shielding board	1
19-11 PL		Parts attachment board	1
19-12 PL		Parts attachment board	1
19-13 PL		Control PCB attachment board	1
19-14 PL		Wiring blind cover	1
19-15 PL		Main PCB attachment plate	1
21 FAN		Cooling fan	2
23 FIN		Heat sink (IPM)	1
24 FIN		Heat sink (DM)	1
26 GD		Finger guard	2
61 PCB		Logic PCB	1
62 PCB		Control circuit terminals PCB	1
63 PCB		R ₀₋₁ PCB	1
64 PCB		Main PCB	1
66 PCB		Driver PCB	1
68 PANEL		Digital operator	1
69 RB		Balance resistor	4
70 C		Sunubber capacitor	3
75 WIRE		FTC	1
76 PLUG		Digital operator connection plug	1
80 RS		Current-limiting resistor	1
81 CT		Current sensor	2
91 TRM1		Thermistor	2
200 FIL		Ferrite core	1
201 INS		Insulation	1

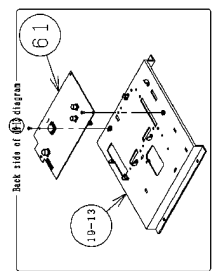

御注文 CUSTOMER	数量 QTY.	受注番号 ORDER No.	作番番号 WORK No.	REV.
	股			
 Hitachi Industrial Equipment Systems Co., Ltd.	SJ700-450~550HFP2 Structure diagram		MARASHINO WORKS DWG. No. 324T835159	SH.
DWN. M. Watanabe CHD. M. Kurita APPD. M. Kurita	REGD. 2007.08.05	JUN. 26 2007 SEP. 05 2007 SEP. 05 2007	#	FRAME SIZE